

# Assembly

## S Series

### S - Swing Module



Ps



Qs



# Assembly steps

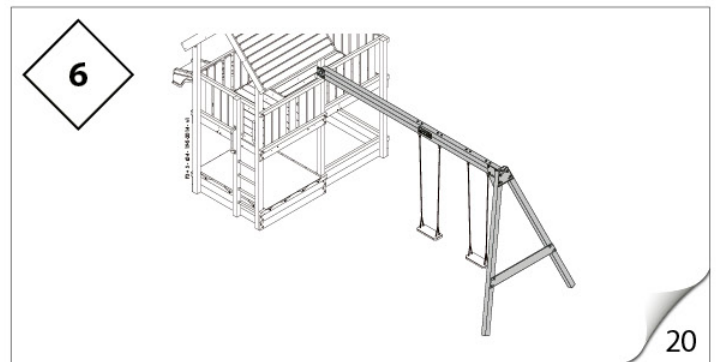
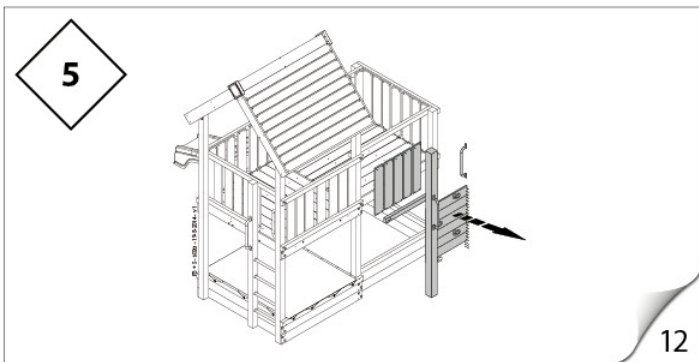
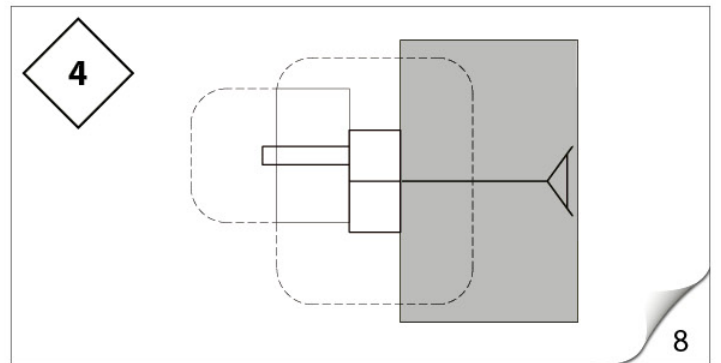
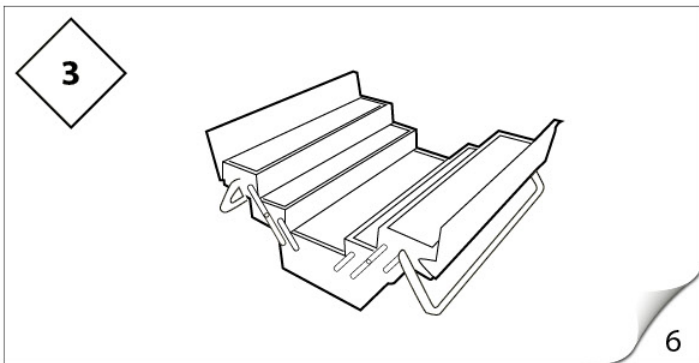
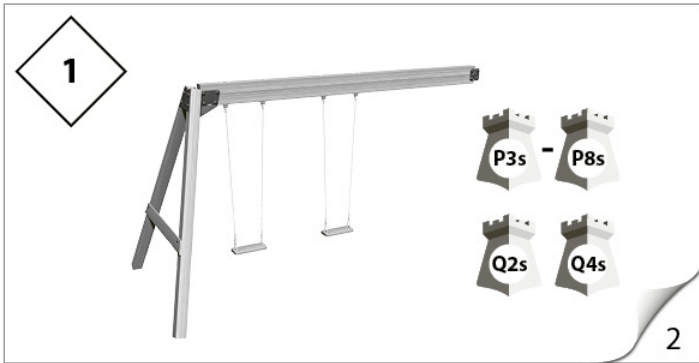

1



+



1x

1x

+



0.11 m<sup>3</sup>



4h

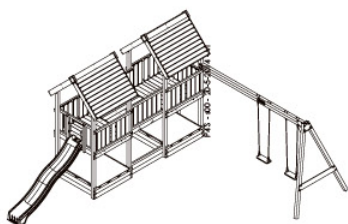

+



1x

1x

+



0.11 m<sup>3</sup>



4h

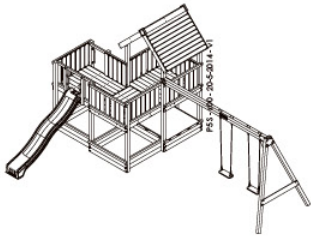

0.11 m<sup>3</sup>

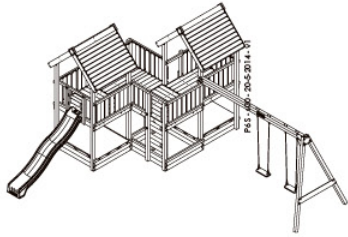

0.11 m<sup>3</sup>

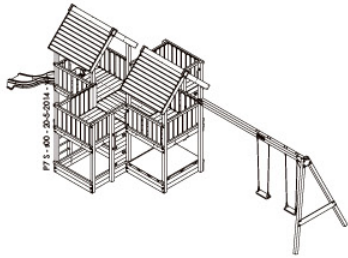

0.11 m<sup>3</sup>

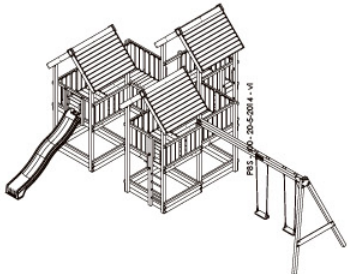

0.11 m<sup>3</sup>

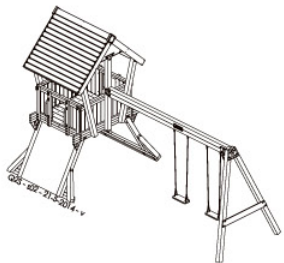

0.12 m<sup>3</sup>

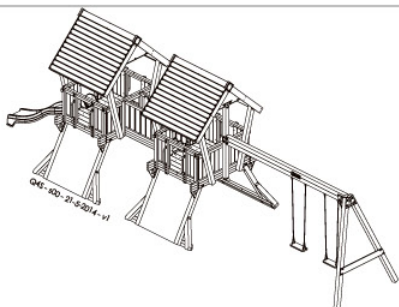

0.12 m<sup>3</sup>



# 2.1

## Content S - Swing Module Start

14\_103\_101\_10

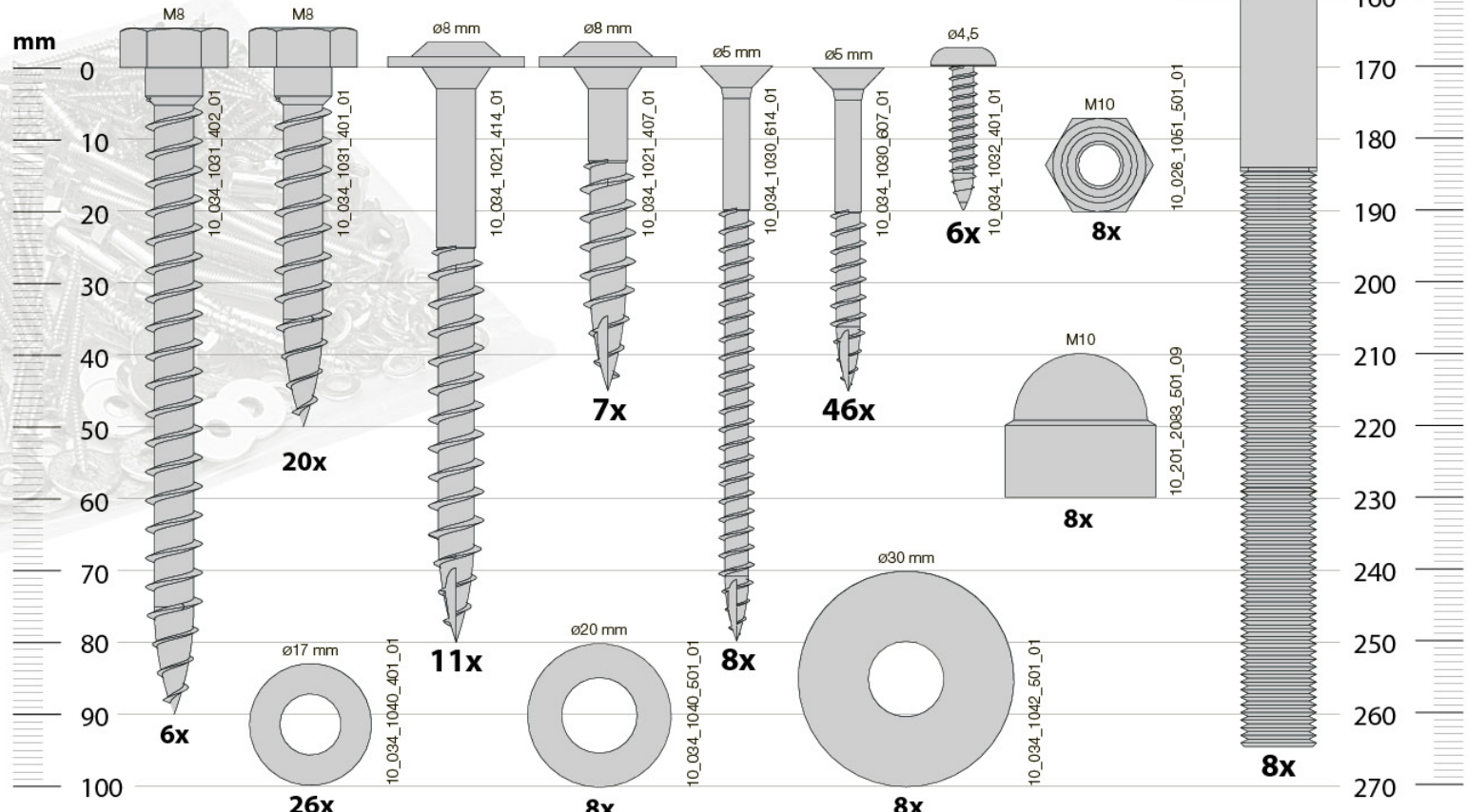
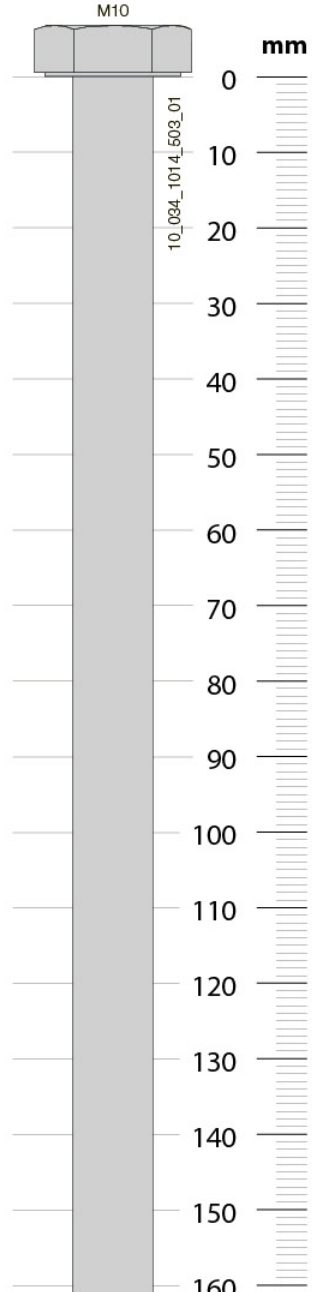
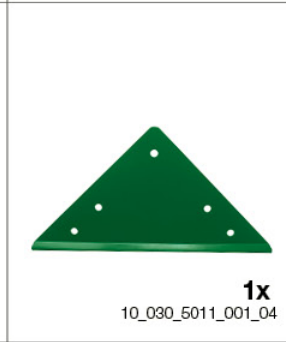
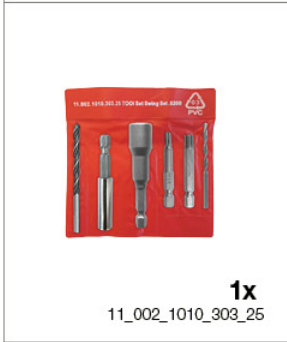
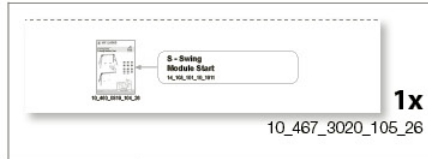

# Tools

11\_002\_1010\_303\_25



**T25** 10\_042\_7093\_158\_01 **1x**

**ø5 mm** 10\_036\_7012\_140\_01 **1x**

**T40** 10\_028\_7091\_160\_01 **1x**

**ø3,5 mm** 10\_037\_7052\_160\_01 **1x**

**T40** 10\_042\_7085\_158\_01 **1x**

**M8** 10\_036\_7057\_142\_01 **1x**

## 2.2

### Content S - Swing Seats (2pcs)

14\_203\_101\_05

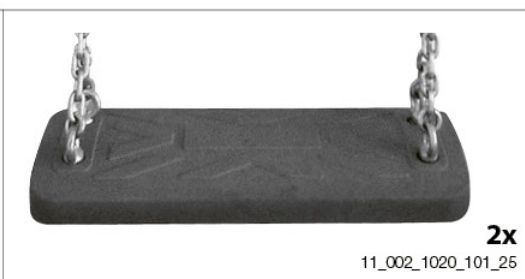

## 2.3

### Timber

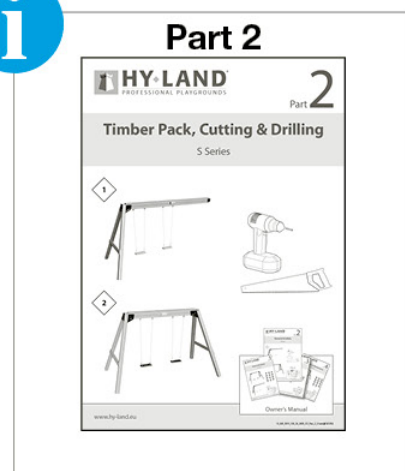
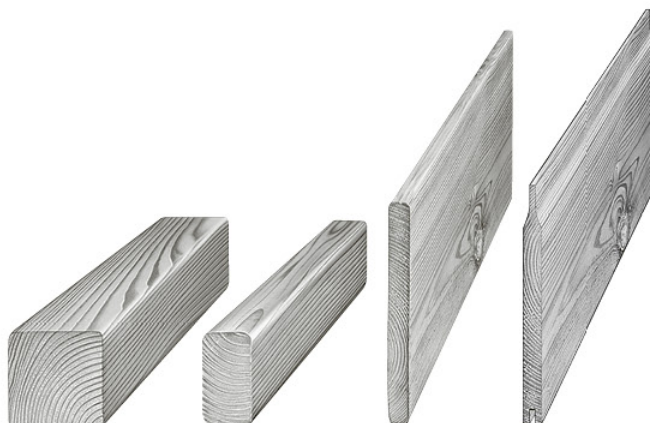

3.1

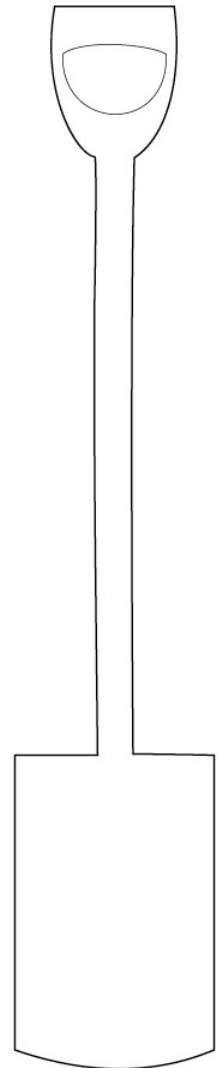
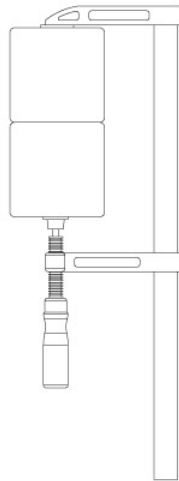
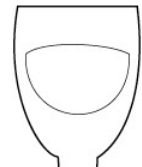
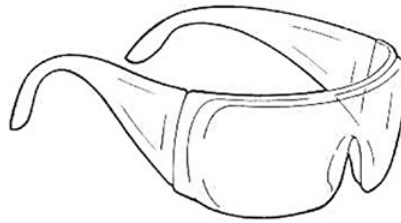
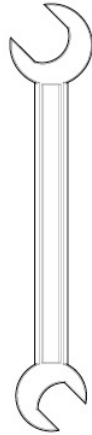
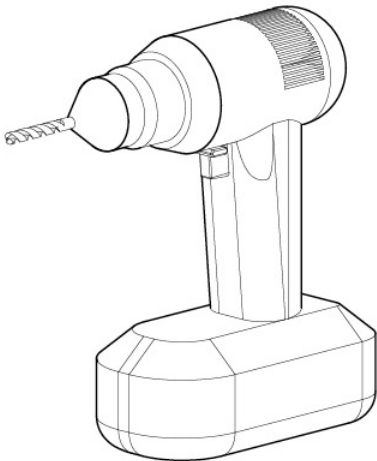
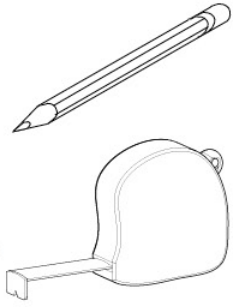
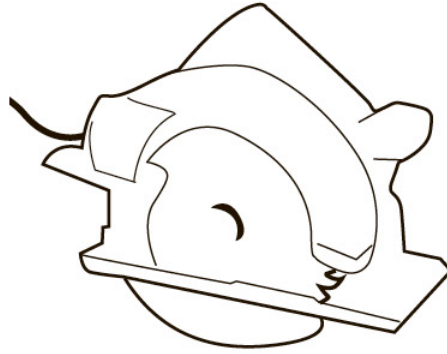
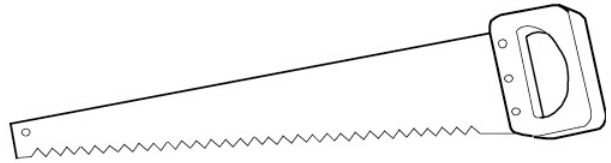
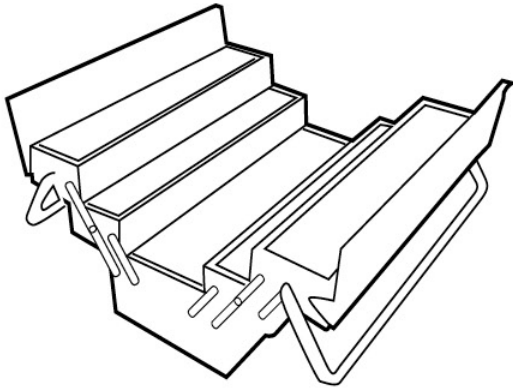

**3.2**

80 mm

45 mm

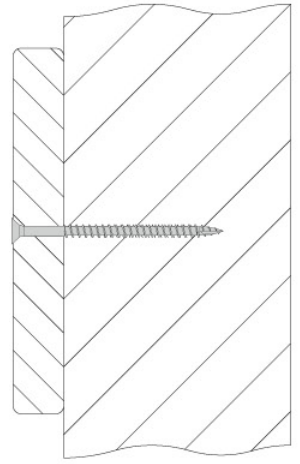
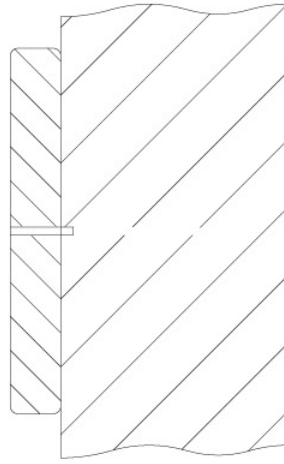
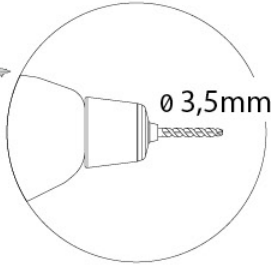

80 mm

45 mm

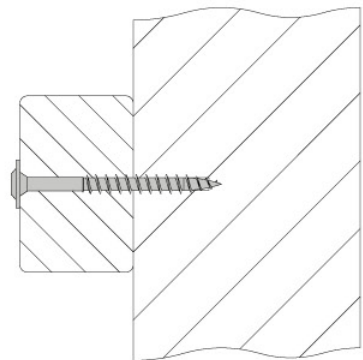
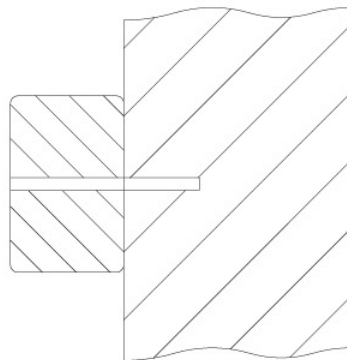
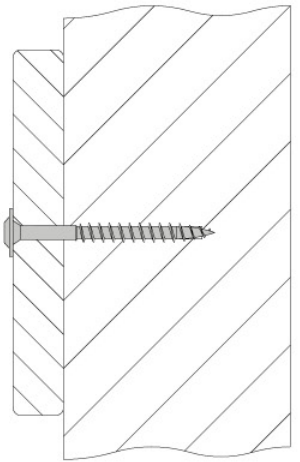
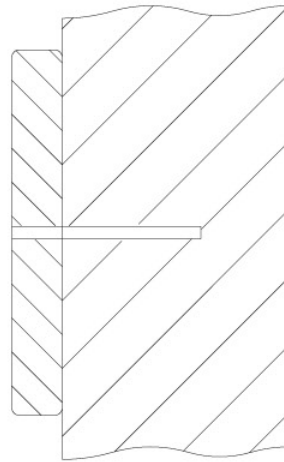
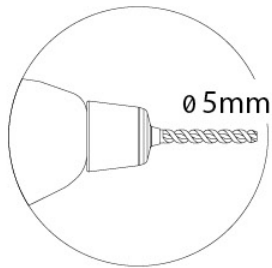

90 mm

50 mm

80 mm

45 mm

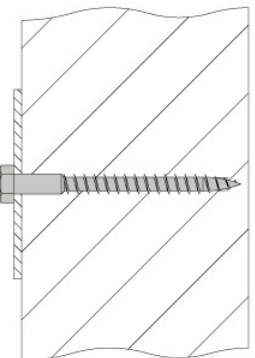
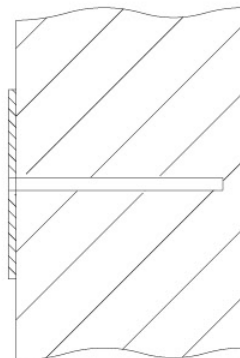
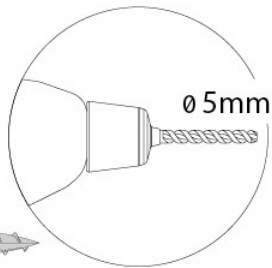

4.1a

P3s

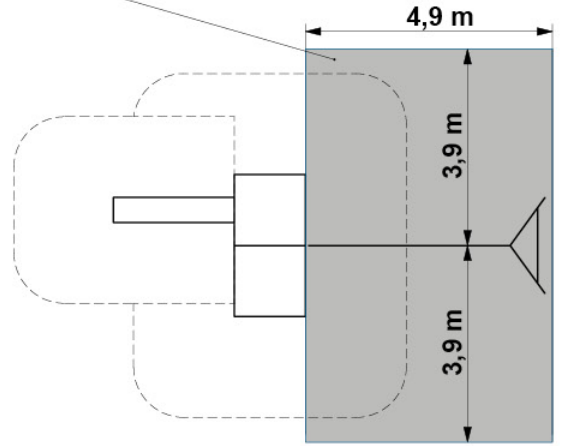
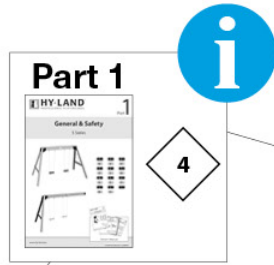
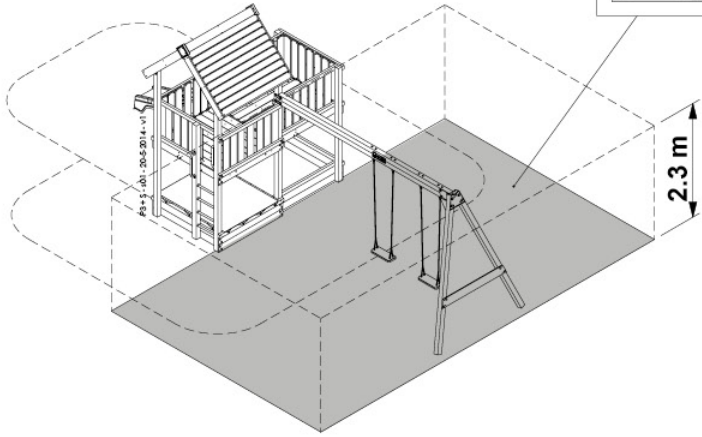

P4s

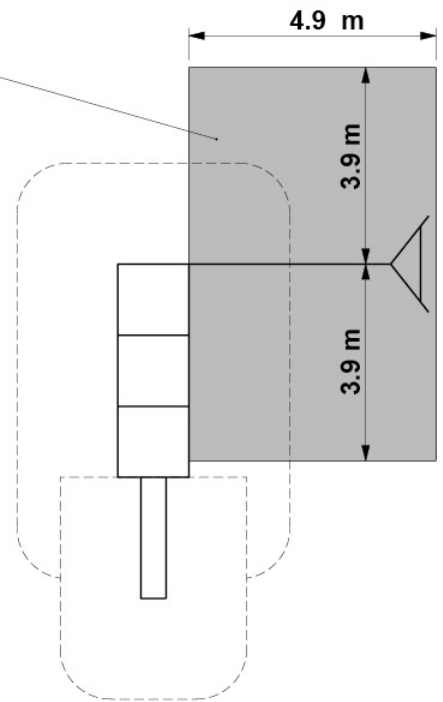
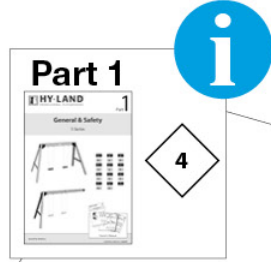
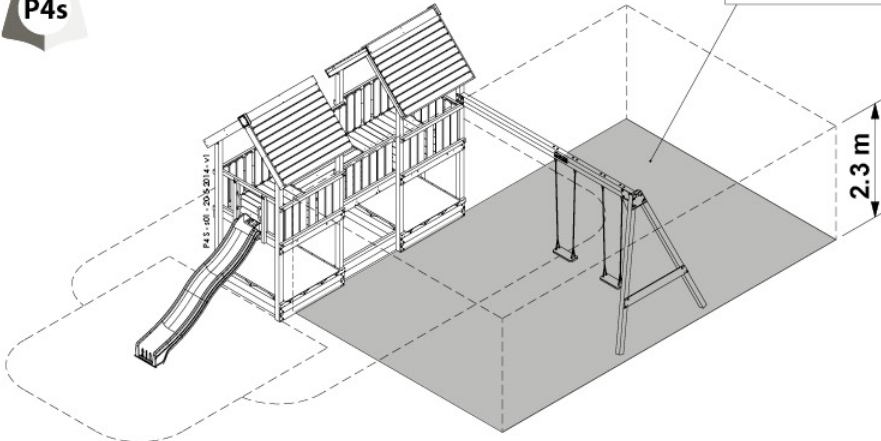

P5s

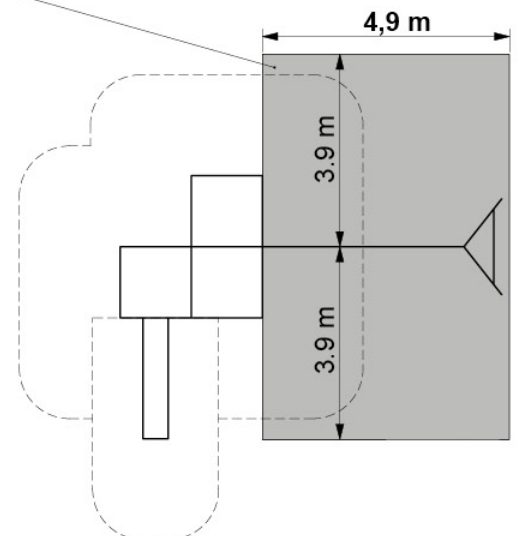
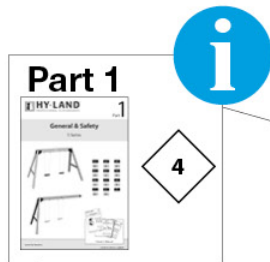
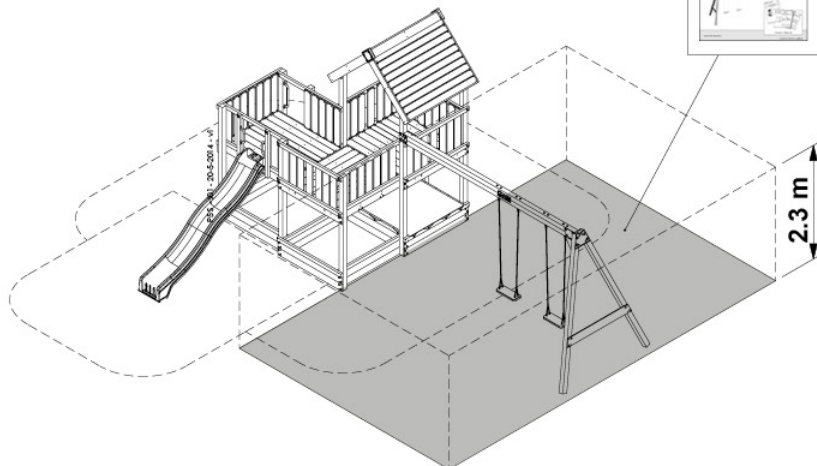



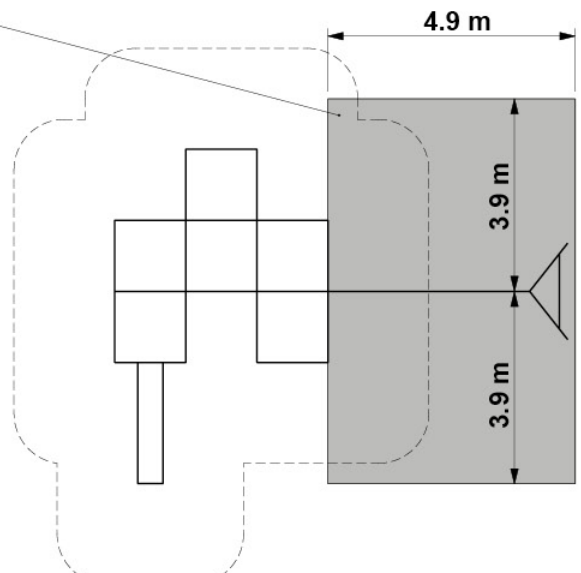
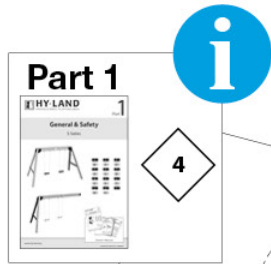
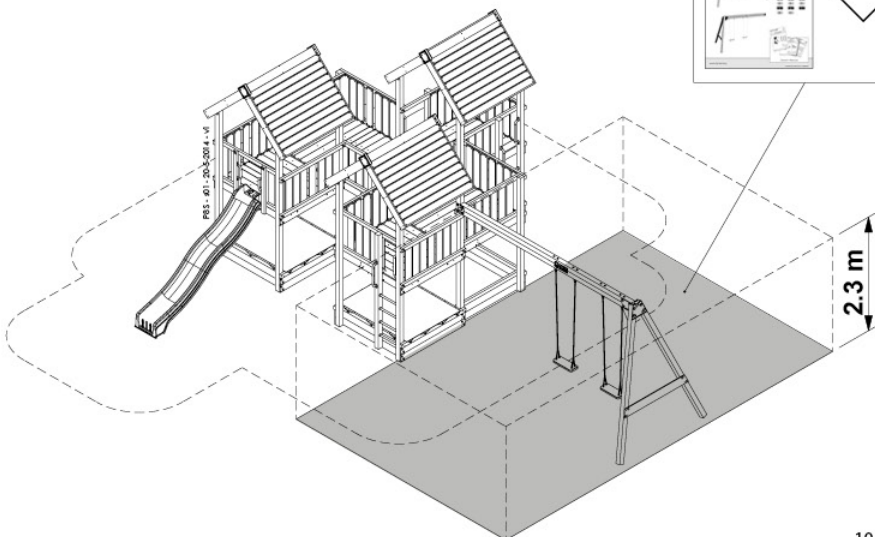
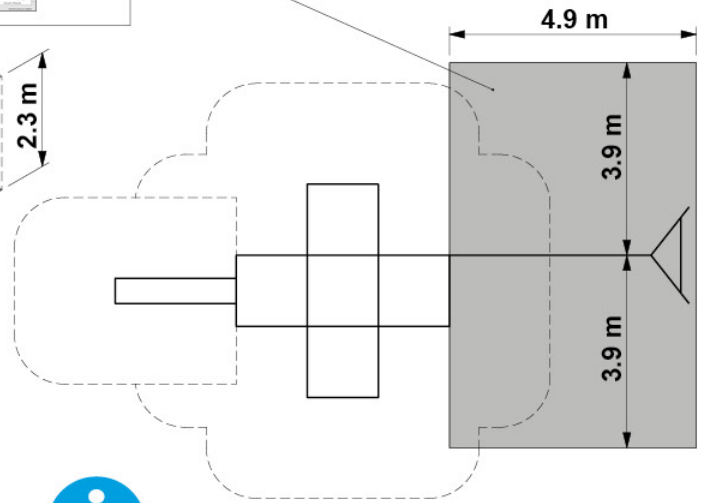
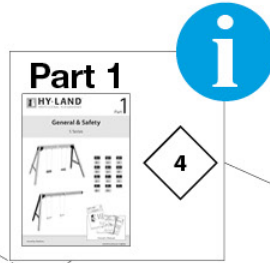
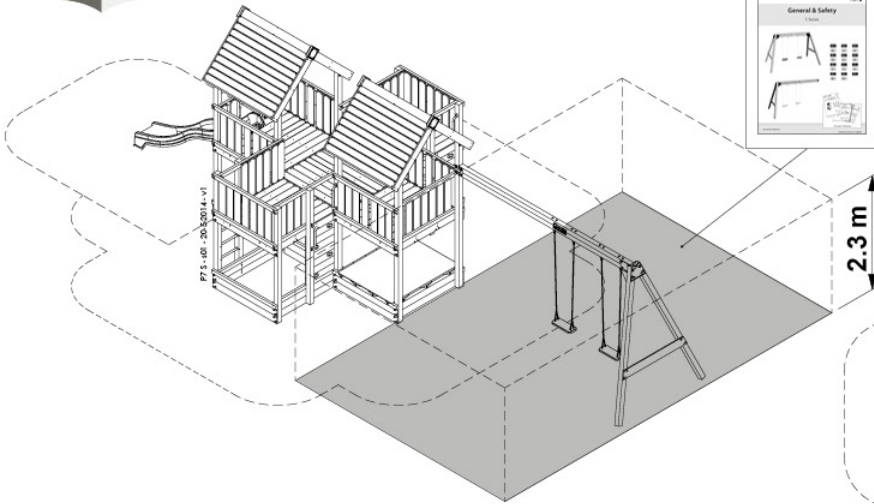
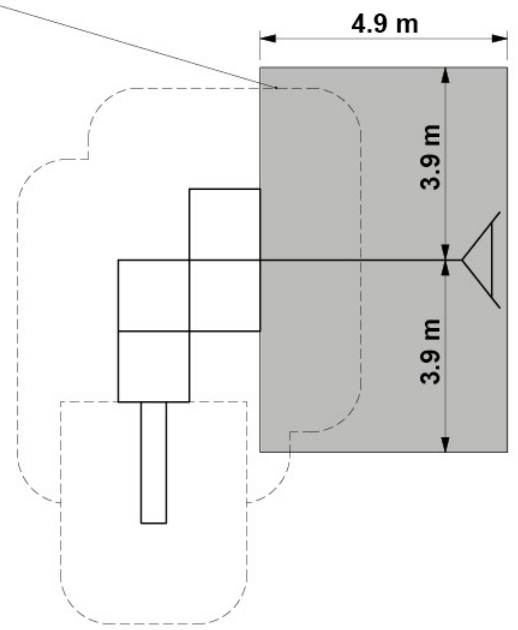
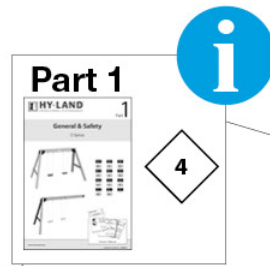
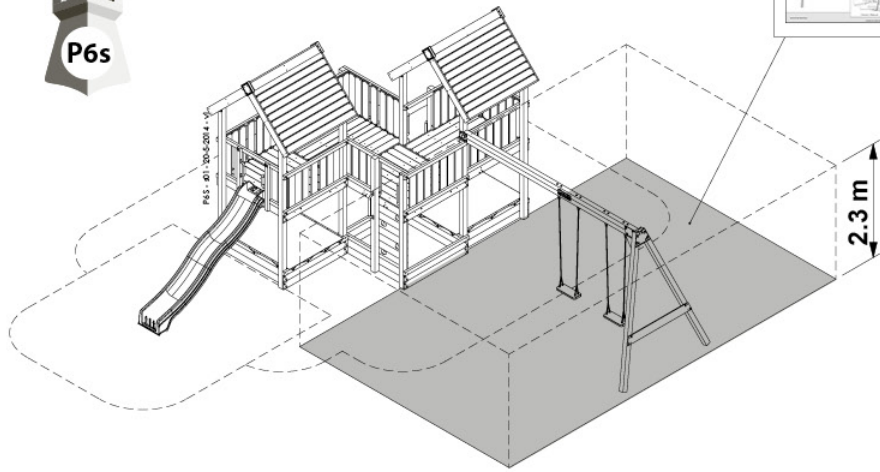

**4.1b**

**Q2s**

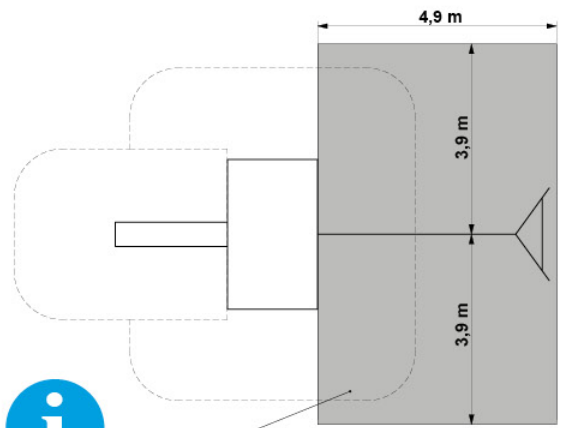
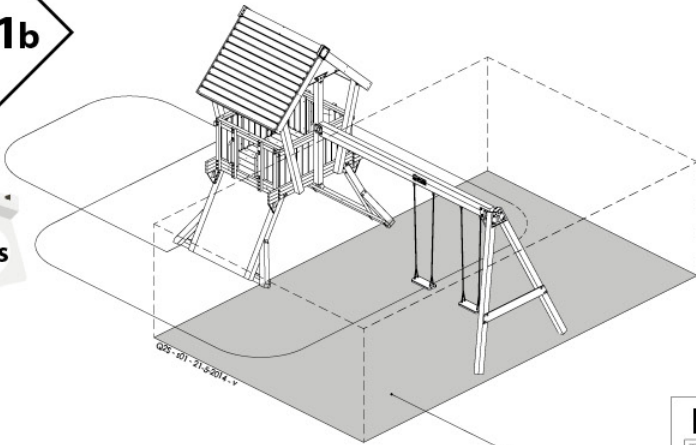

**i**

**Part 1**



**4**

**Q4s**

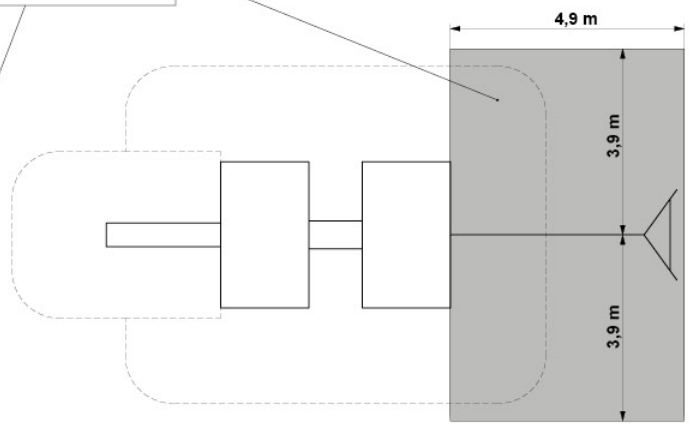
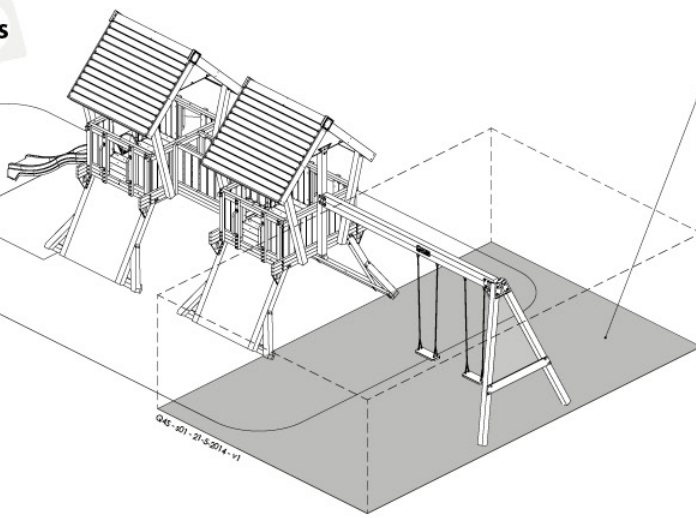

**4.2**

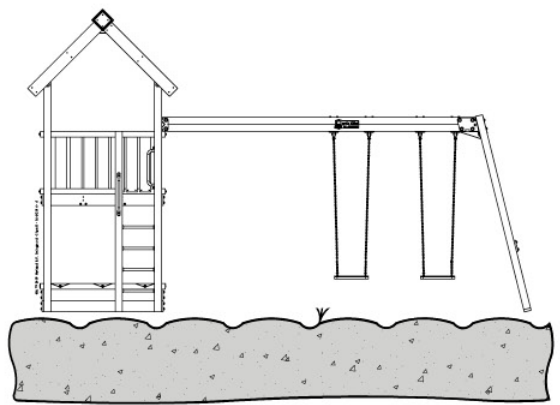
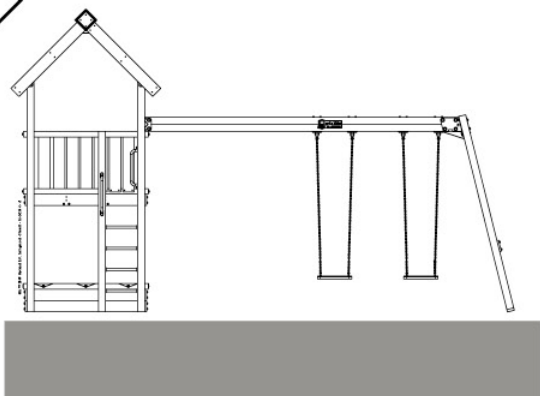

**4.3**



**4.4**

4.3

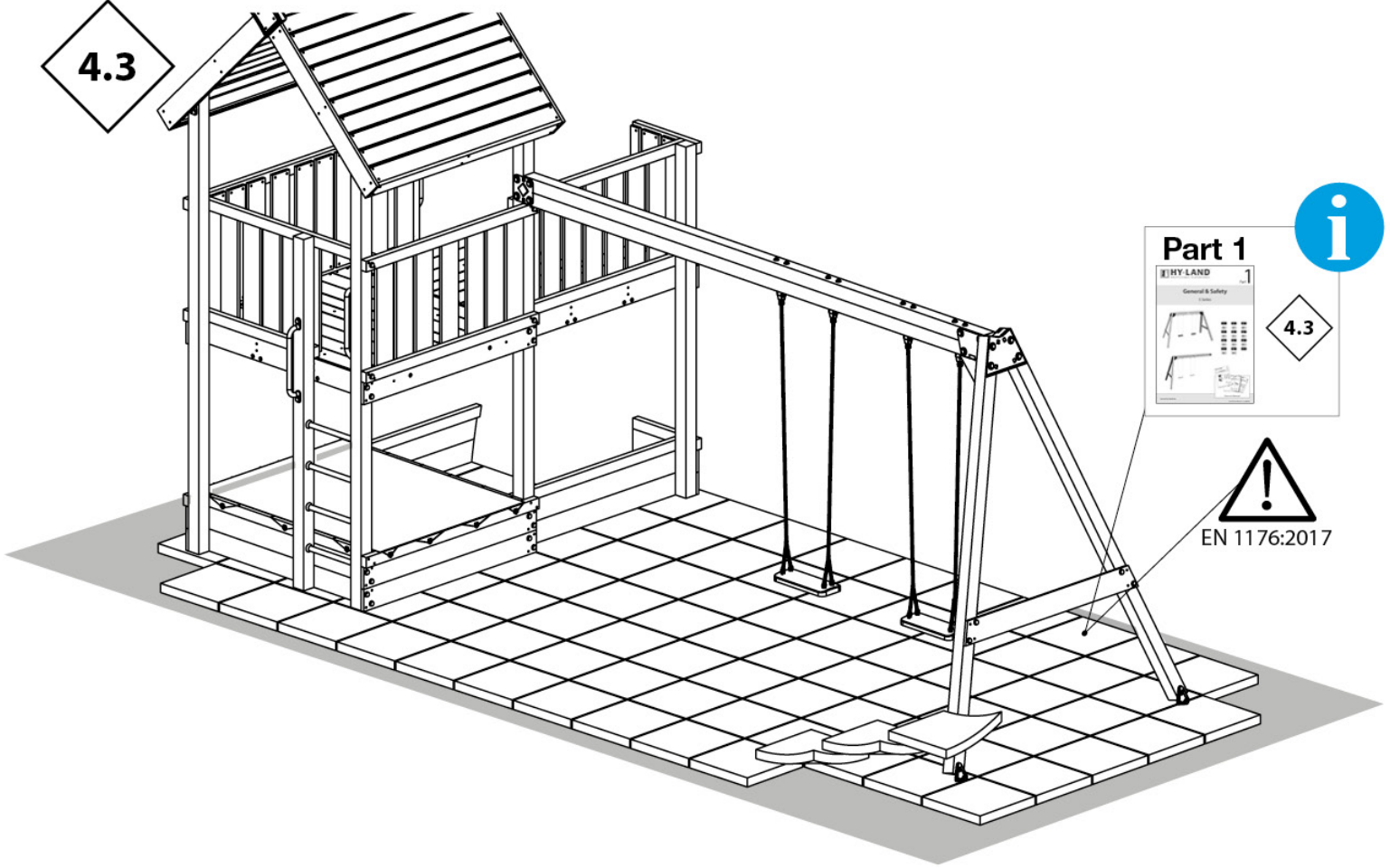

4.4

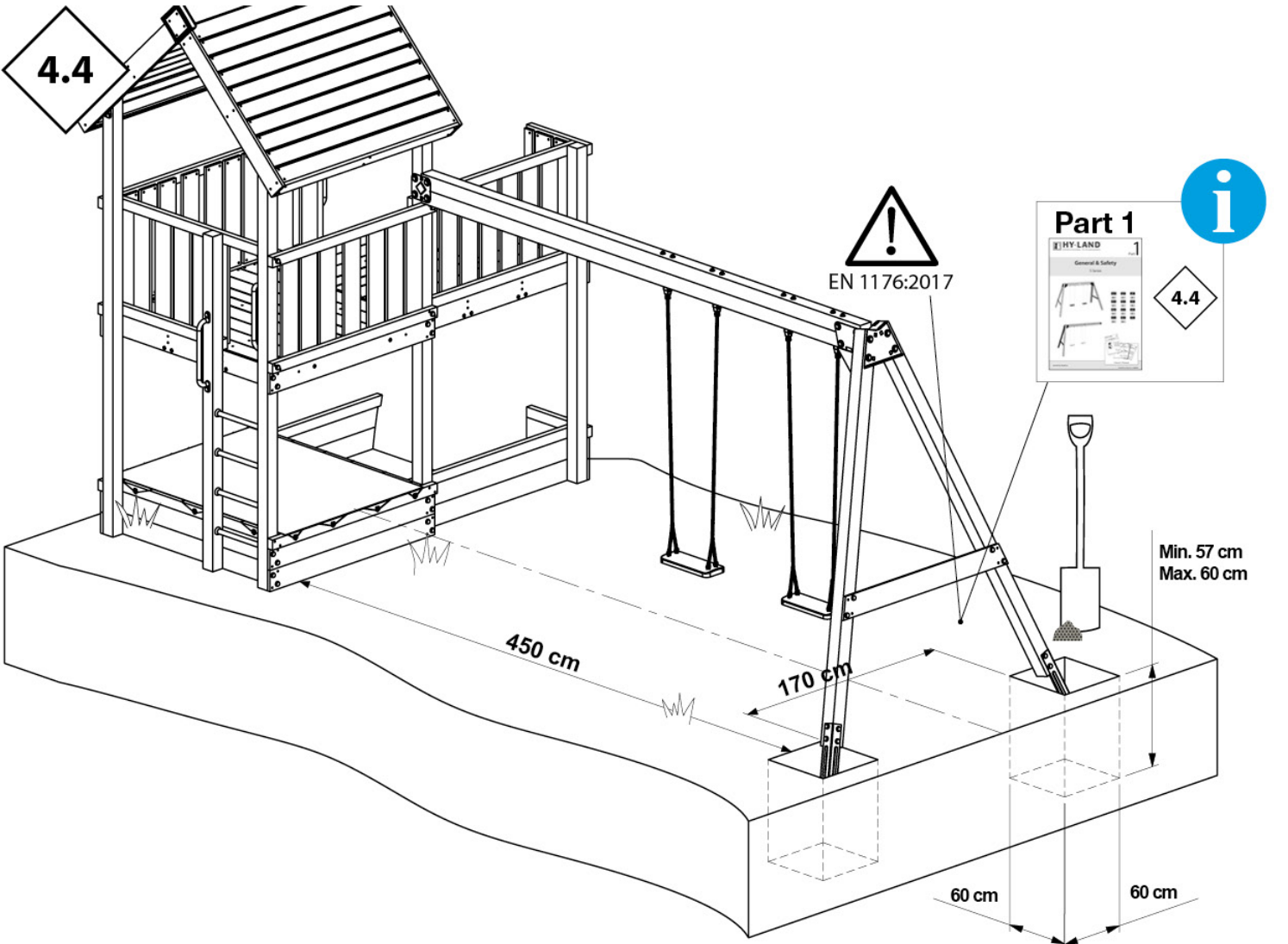

5

P3s

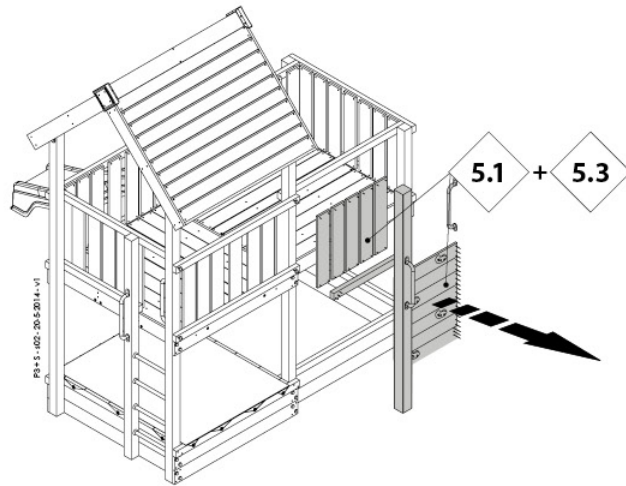

P4s

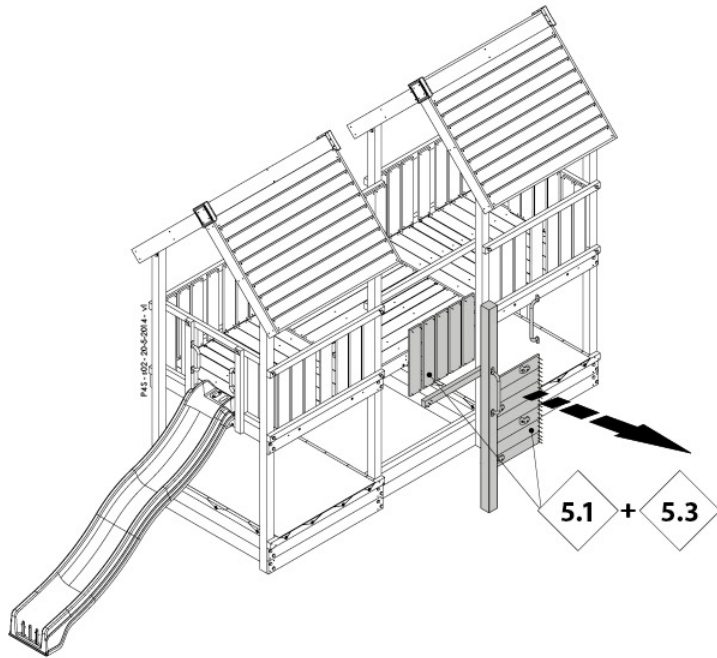

P5s

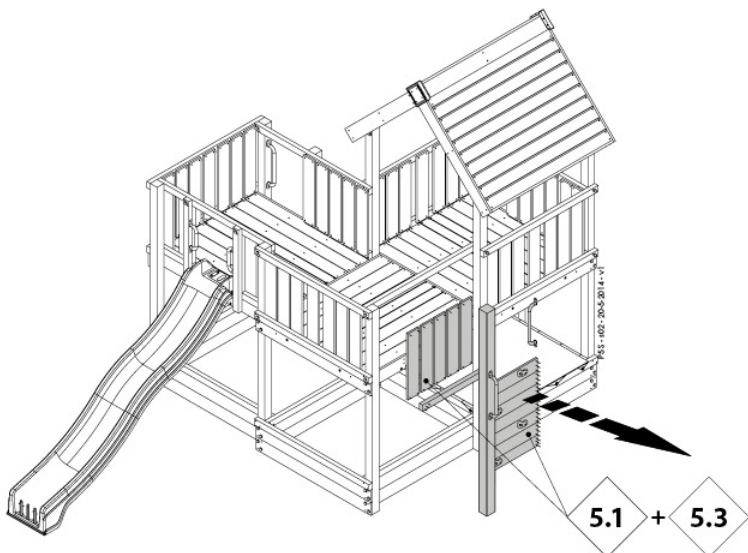

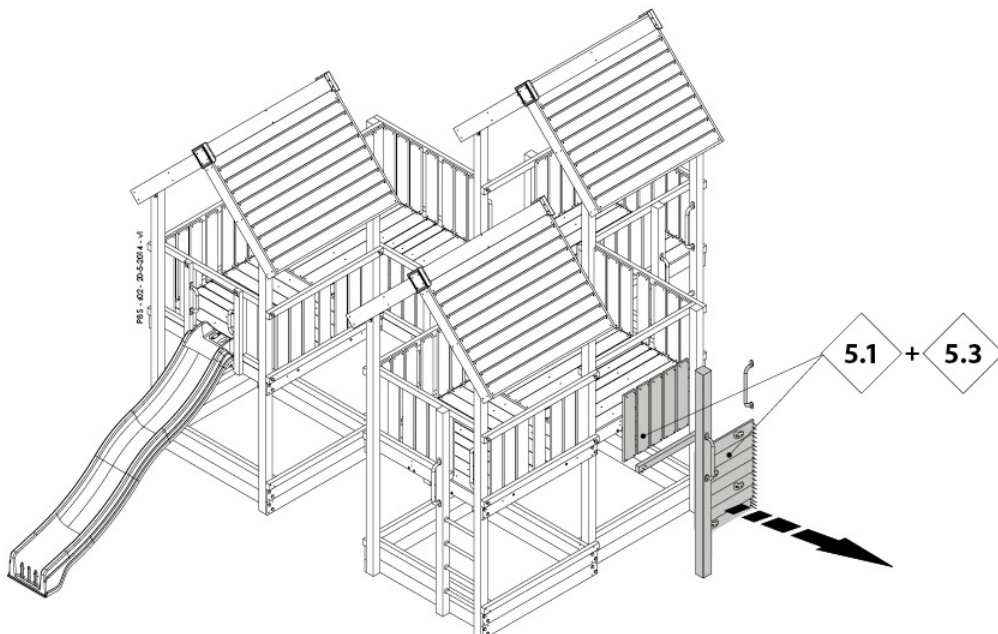
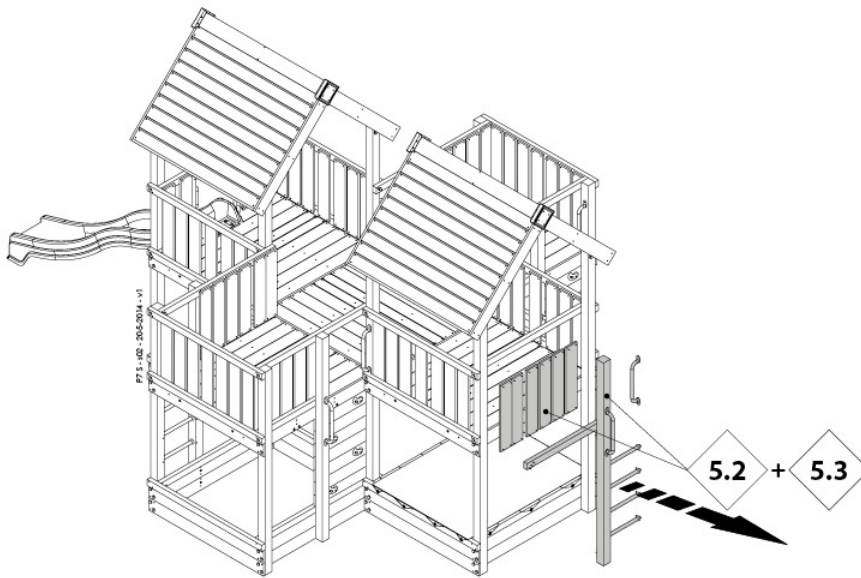
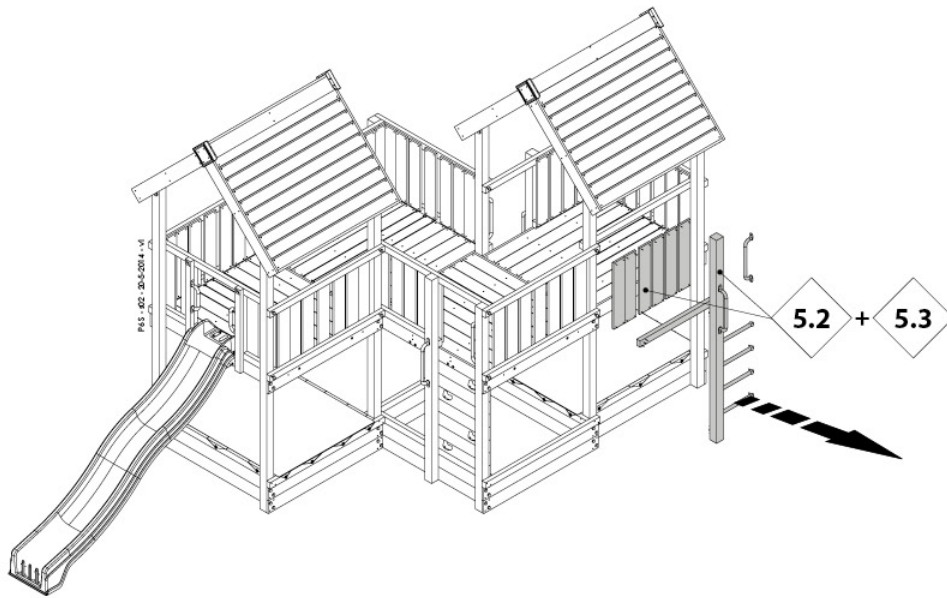

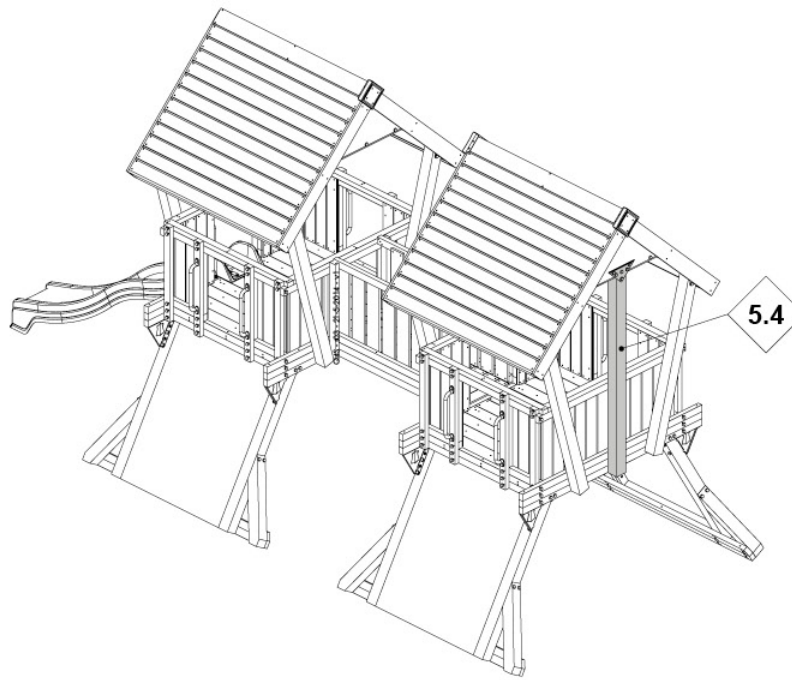
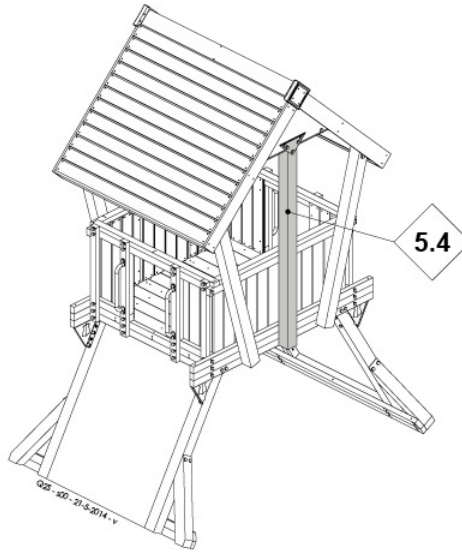

**5.1**

**K (5x)** →

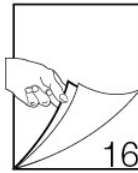

**5.3b**

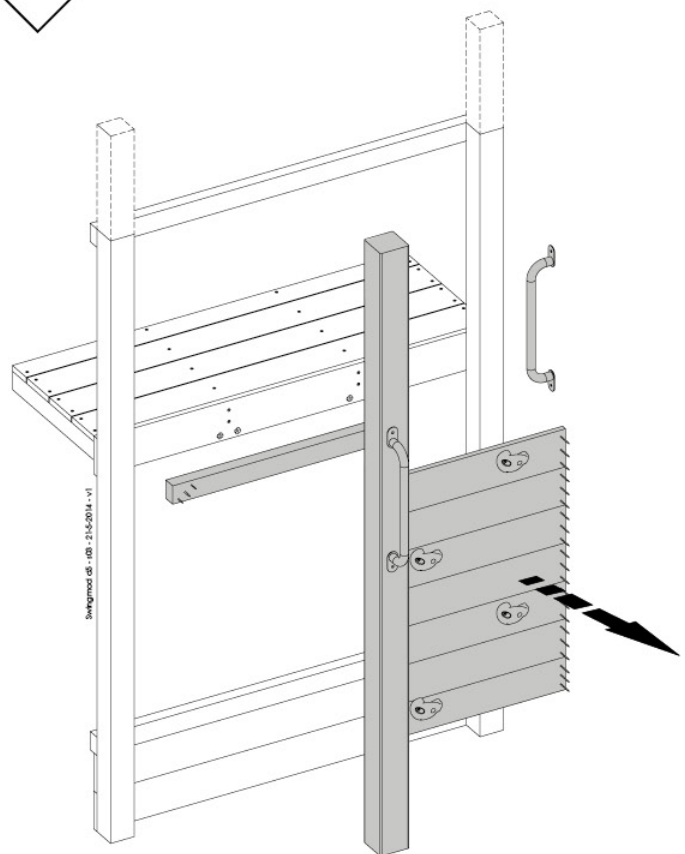
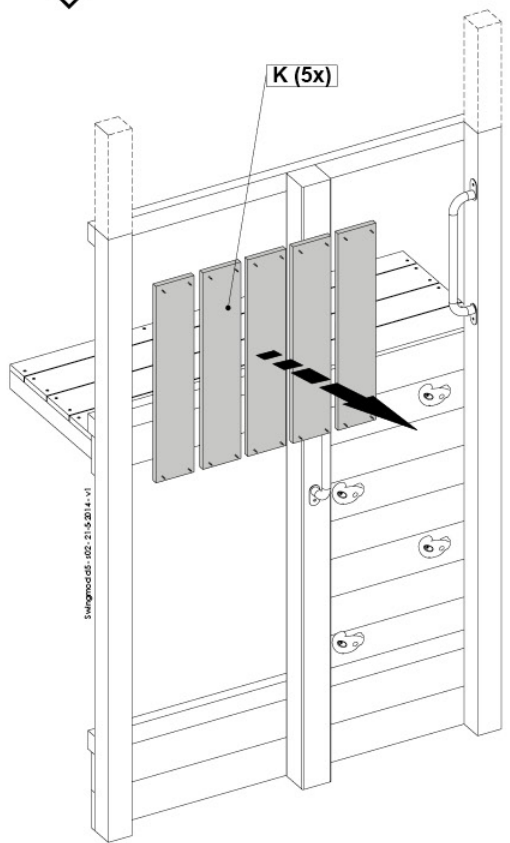

**5.2**

**K (6x)** →

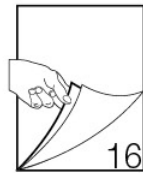

**5.3b**

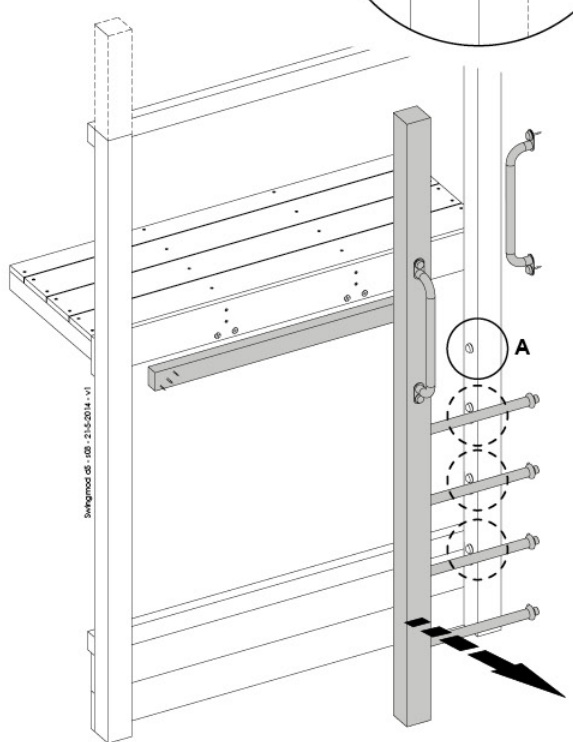
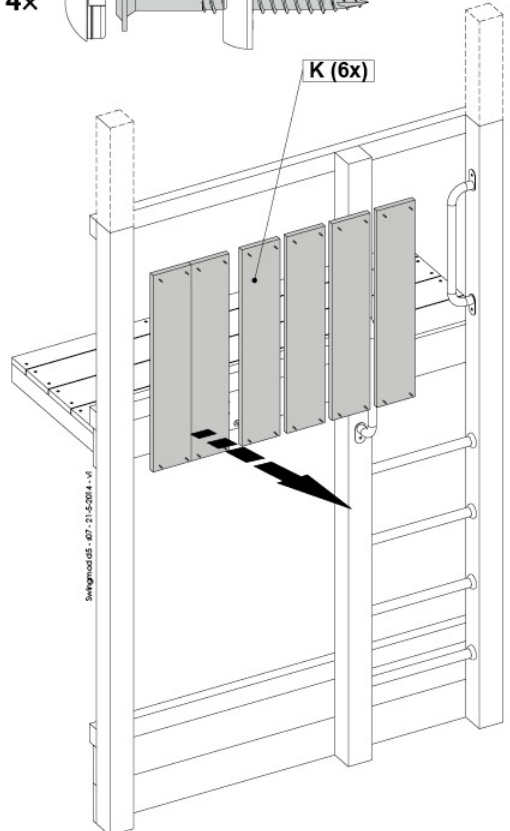
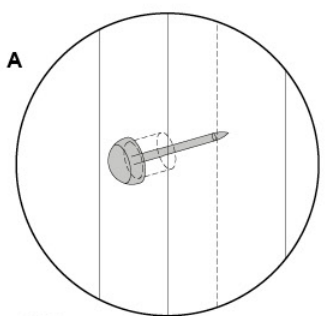
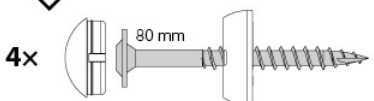

# 5.3a

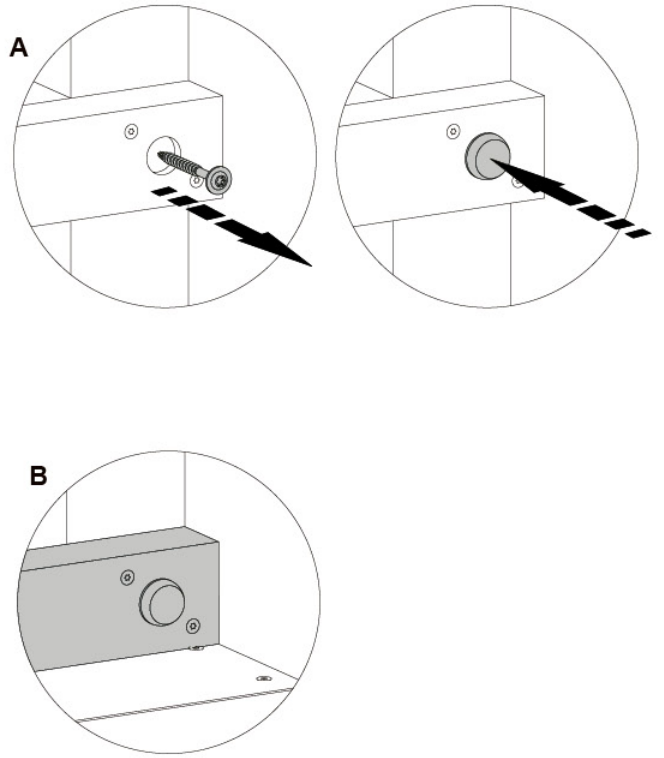
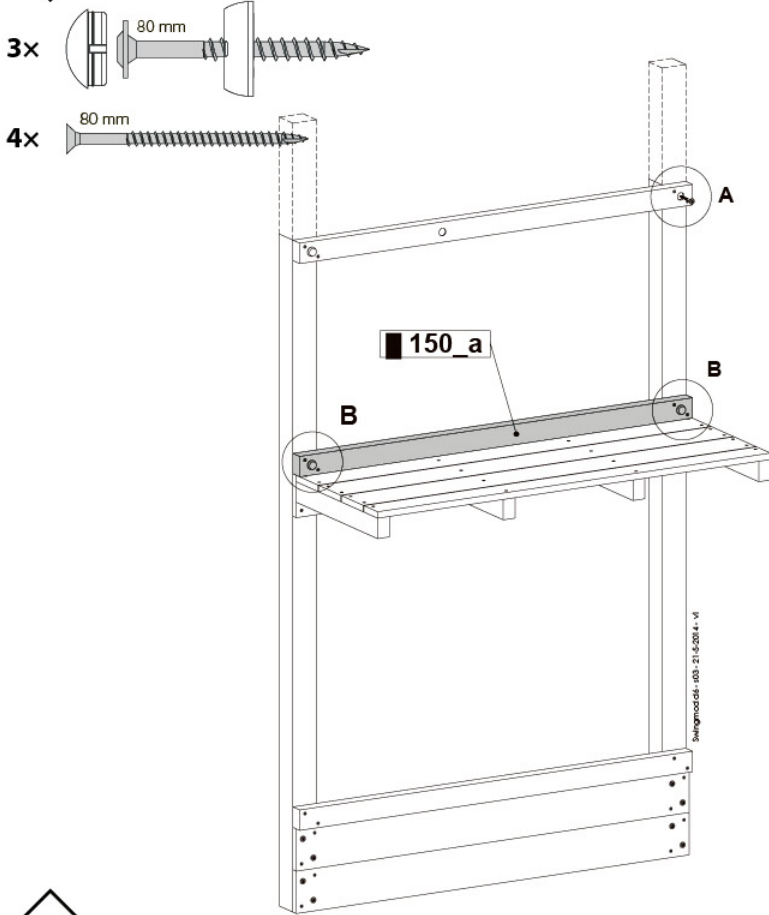

# 5.3b

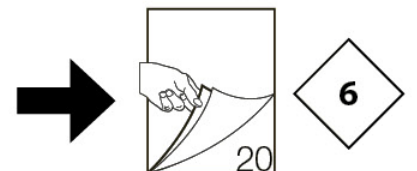
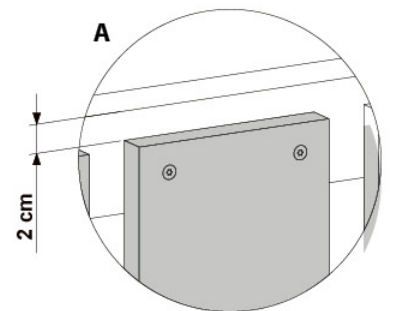
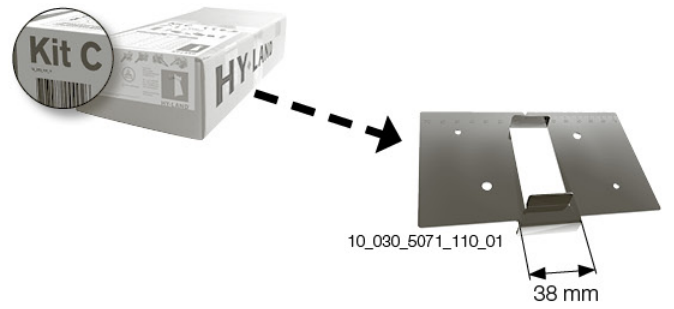
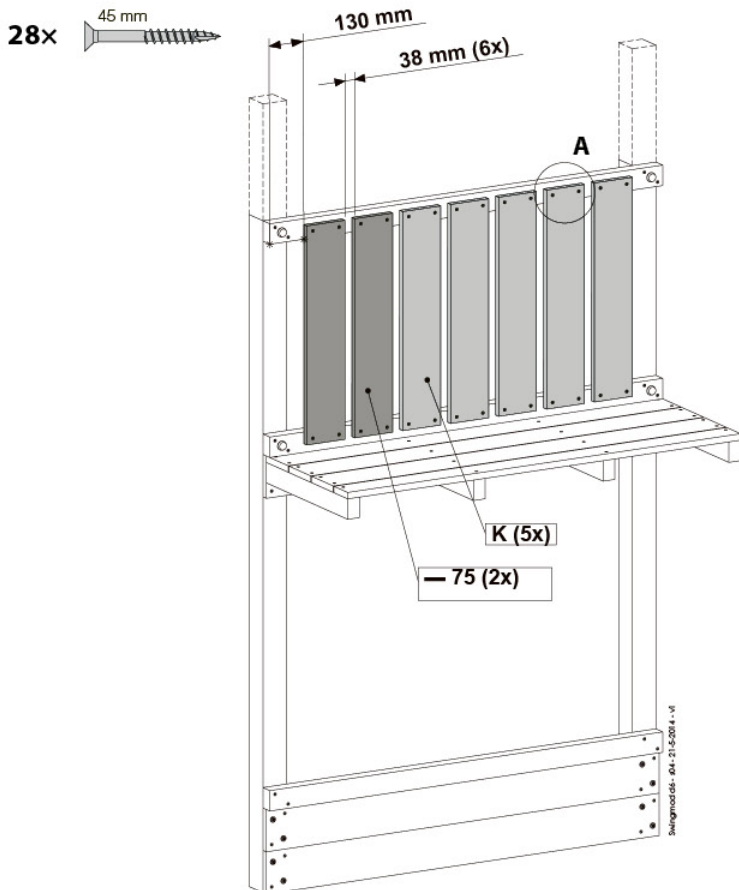



5.4a

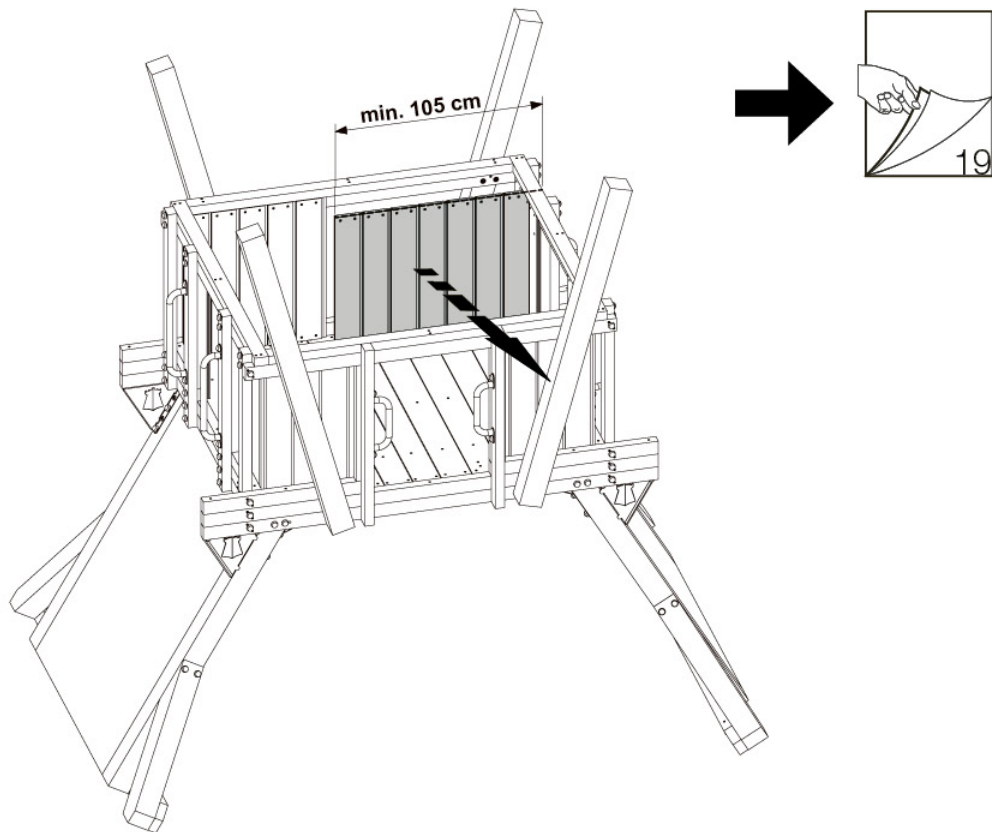

5.4e

5.4b

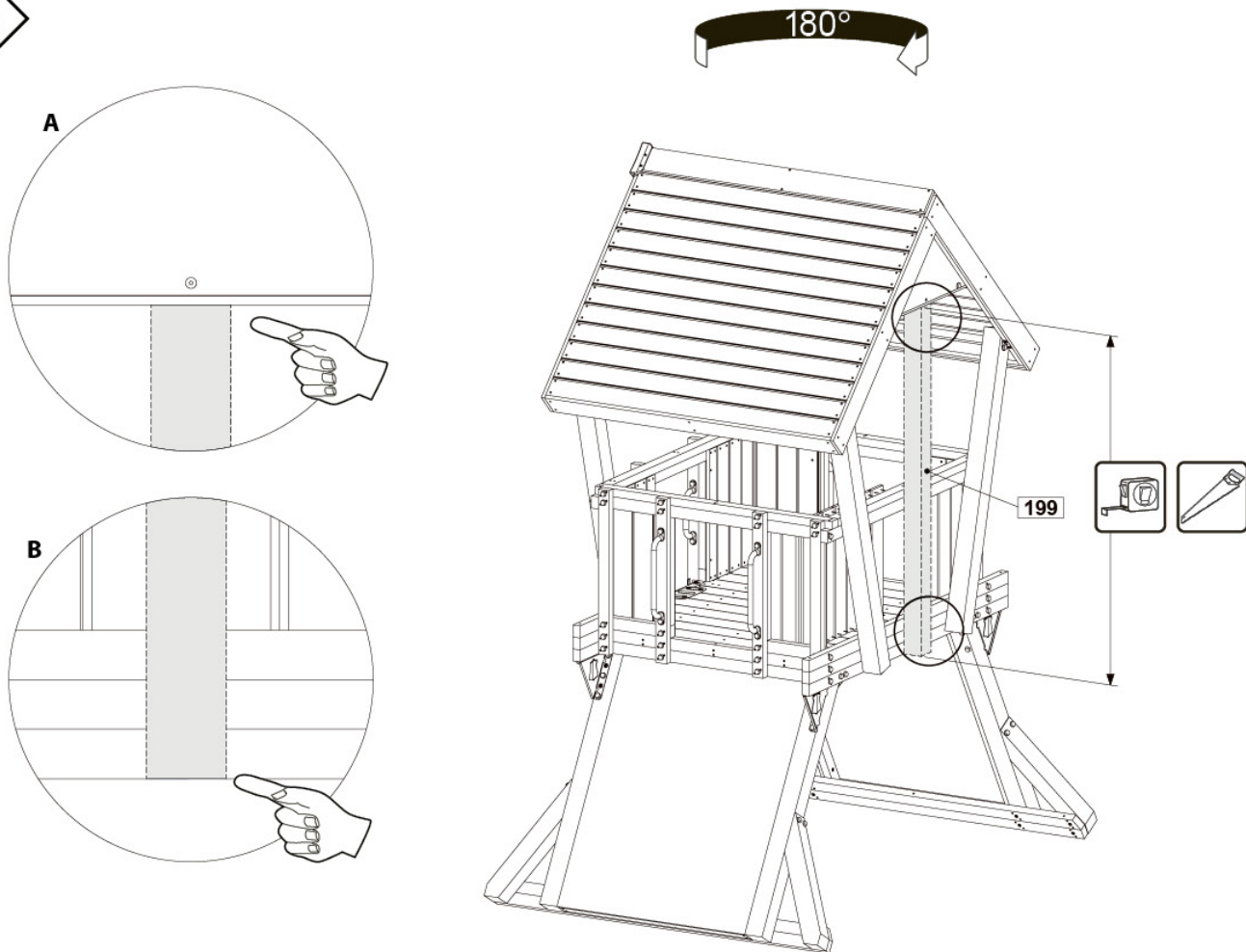

**5.4c**

4x 80 mm

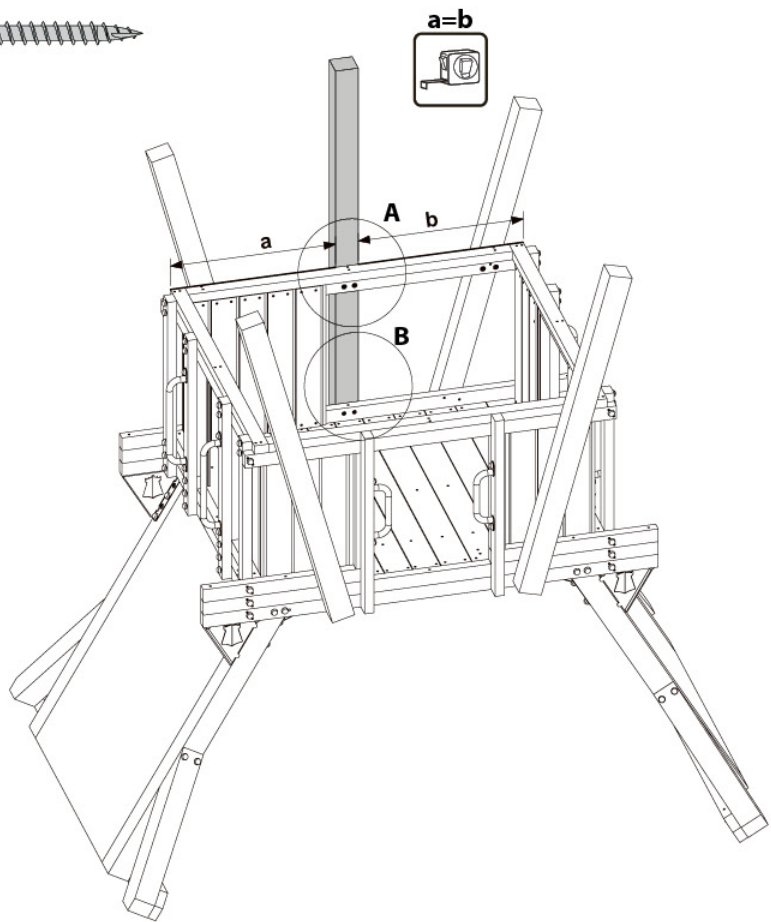

a=b

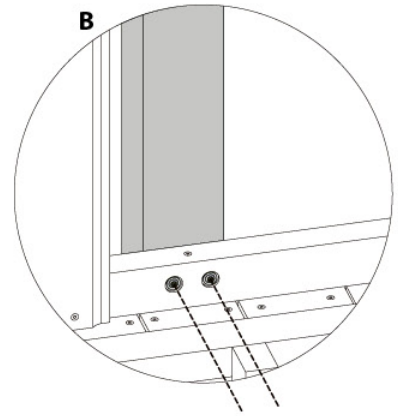
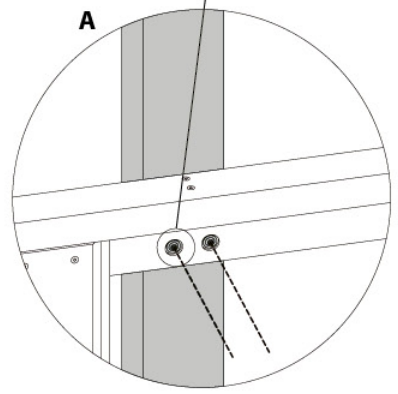
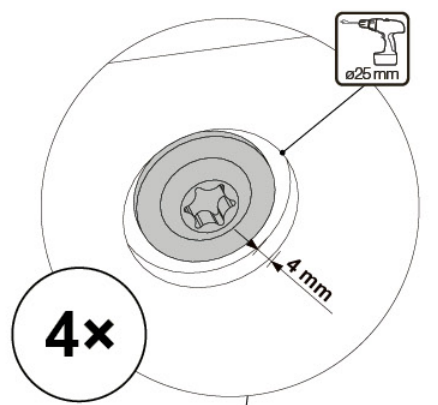

**5.4d**

2x 80 mm

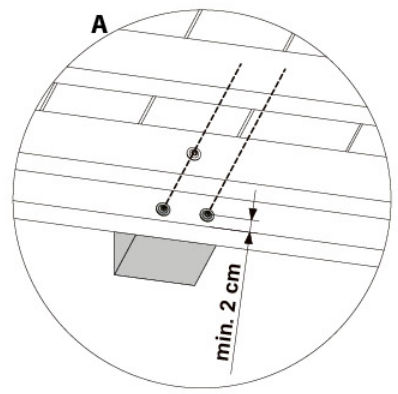
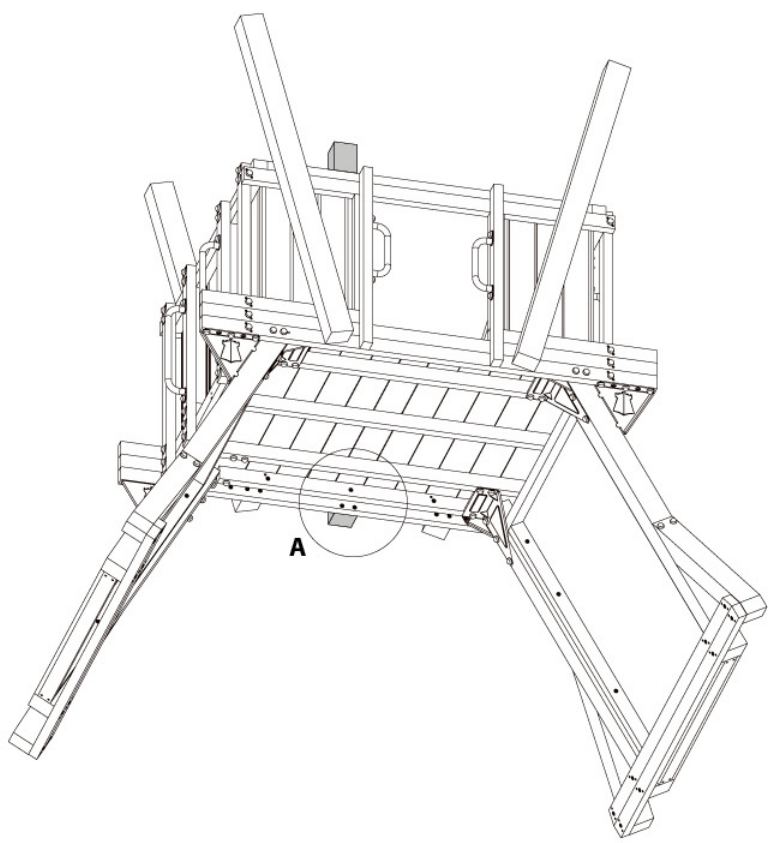

**5.4e**

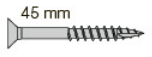
36 - 44x  45 mm

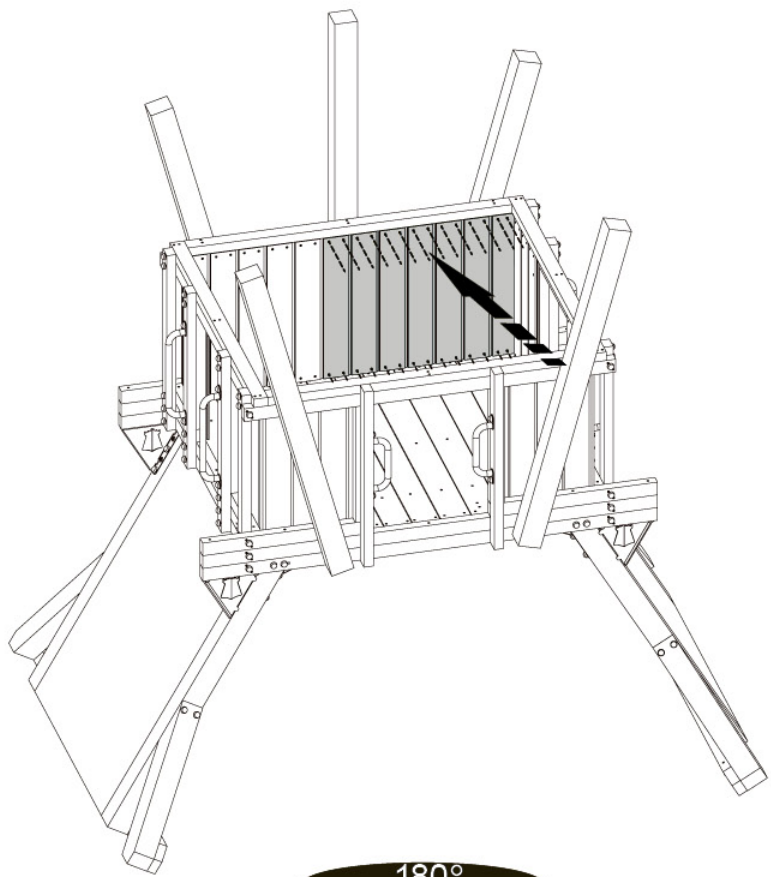

180°

**5.4f**

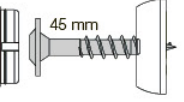
5x  45 mm

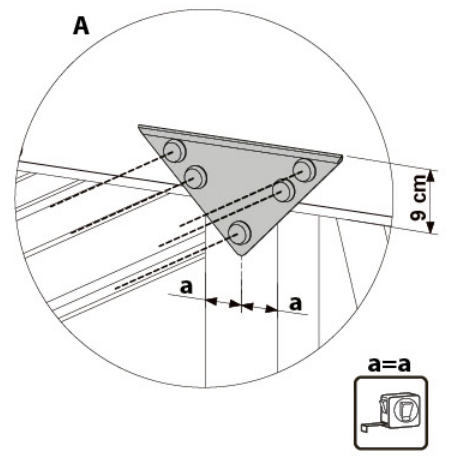
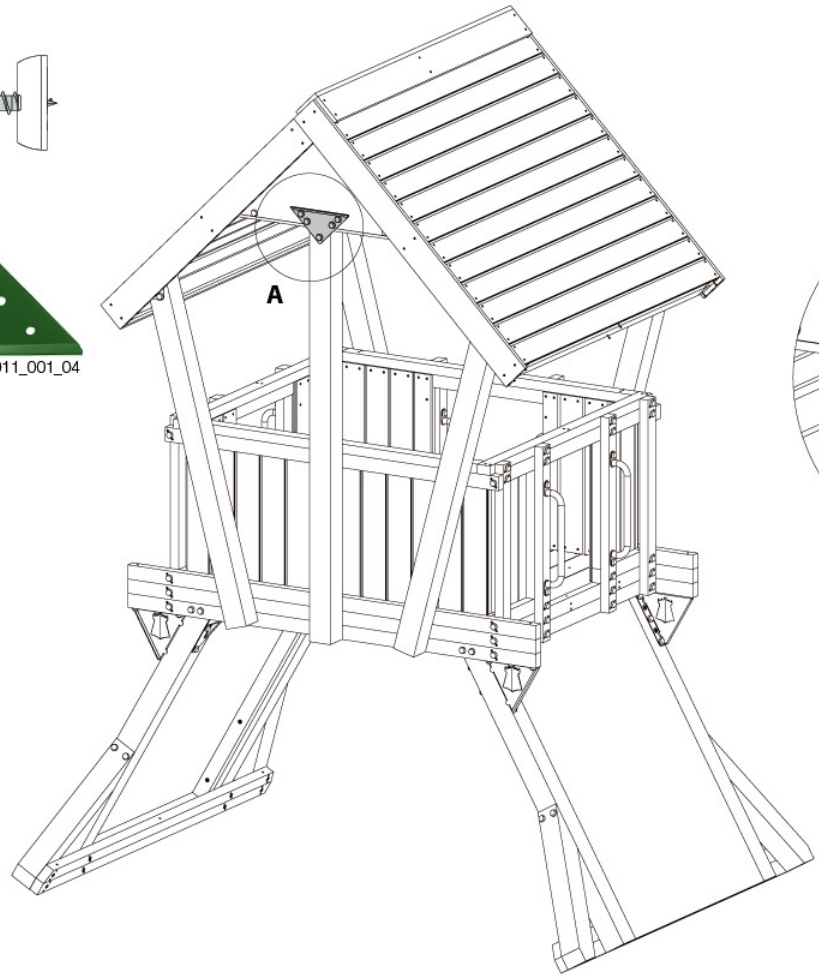
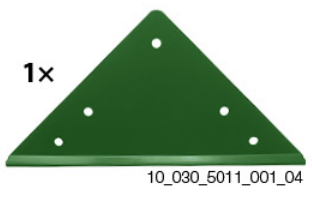

6

P3s

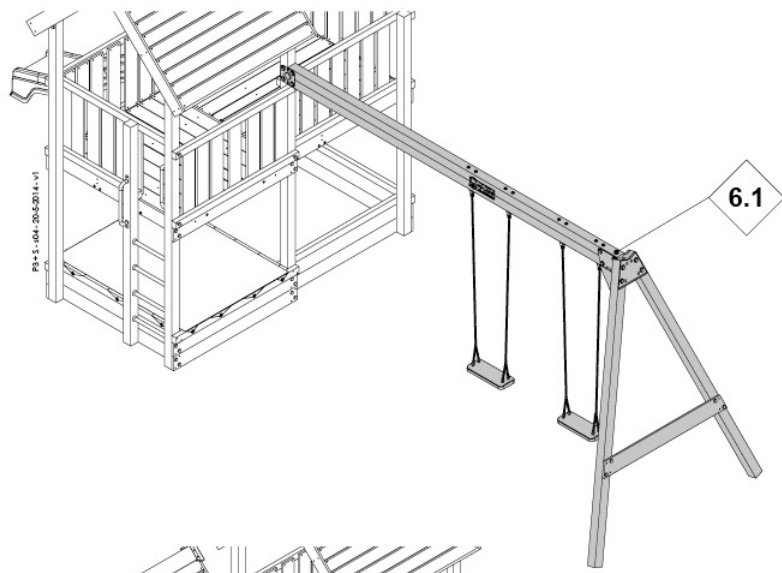

P4s

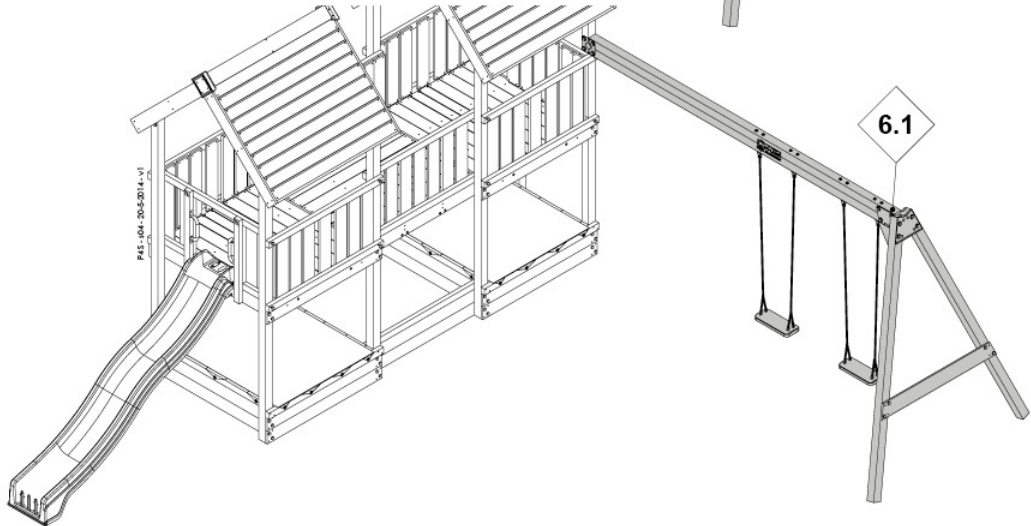

P5s

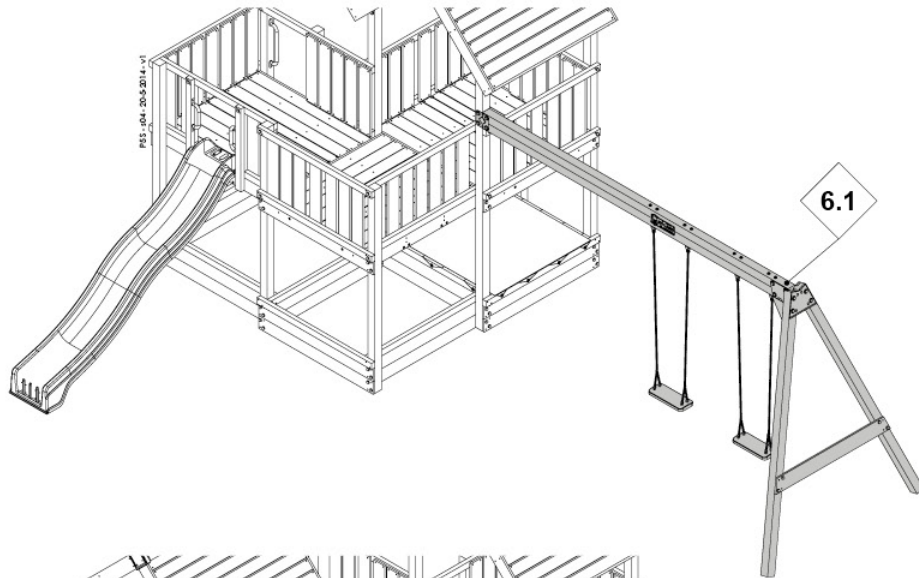

P6s

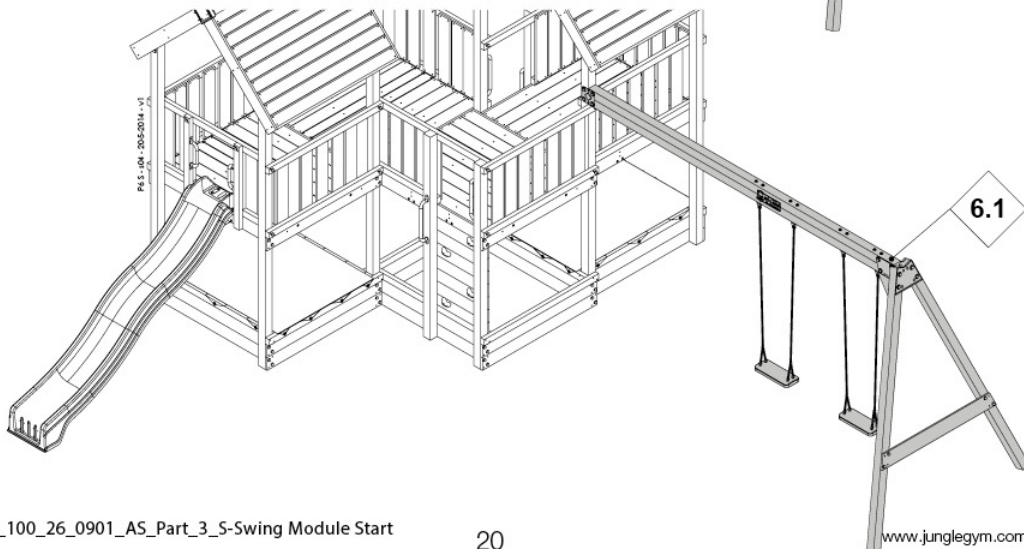



P7s

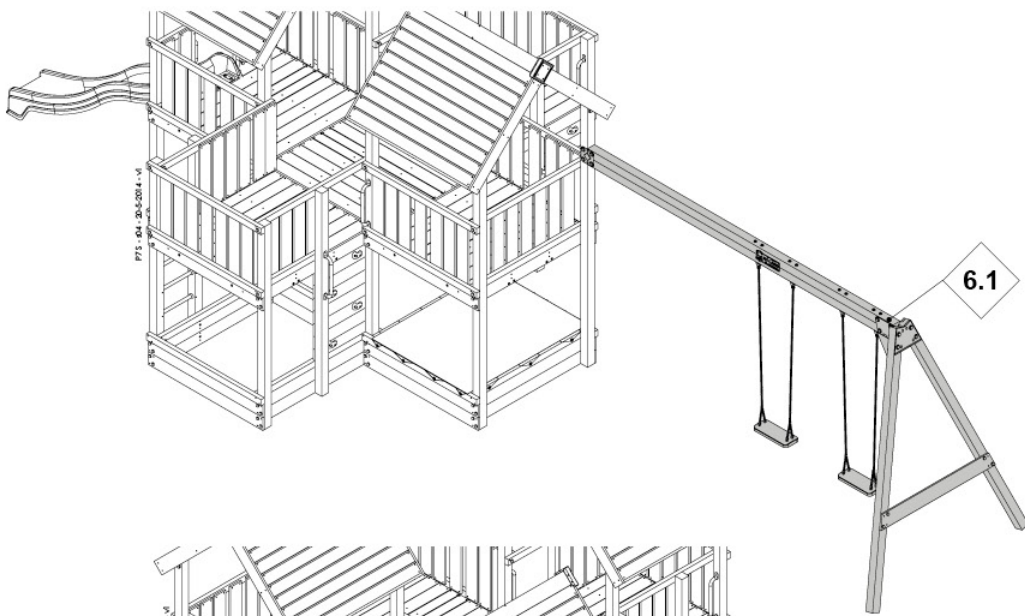

6.1



P8s

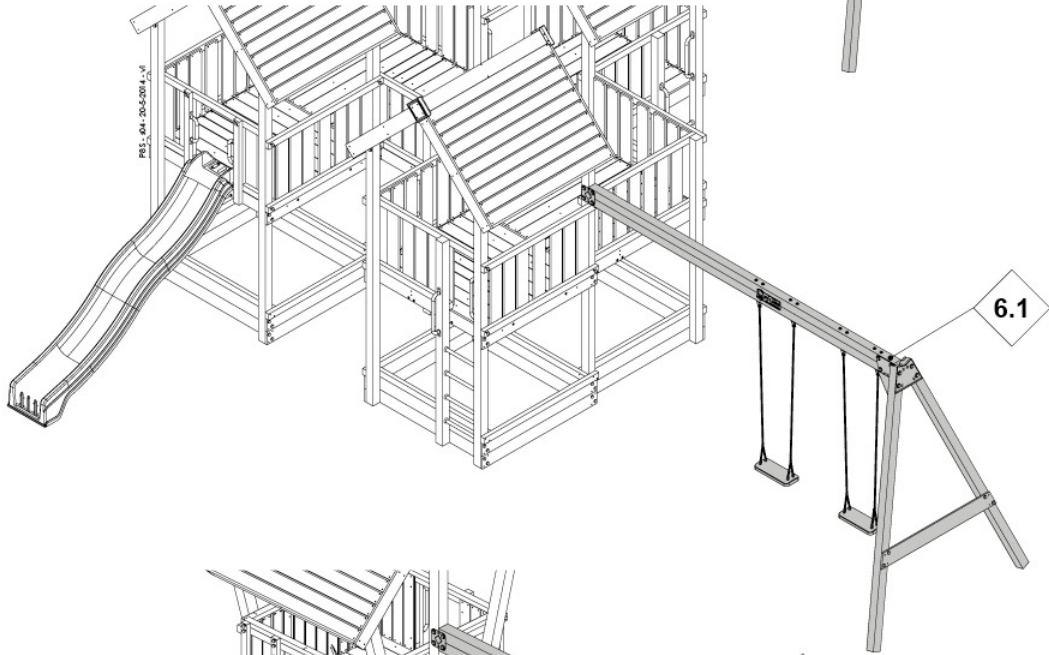

6.1



Q2s

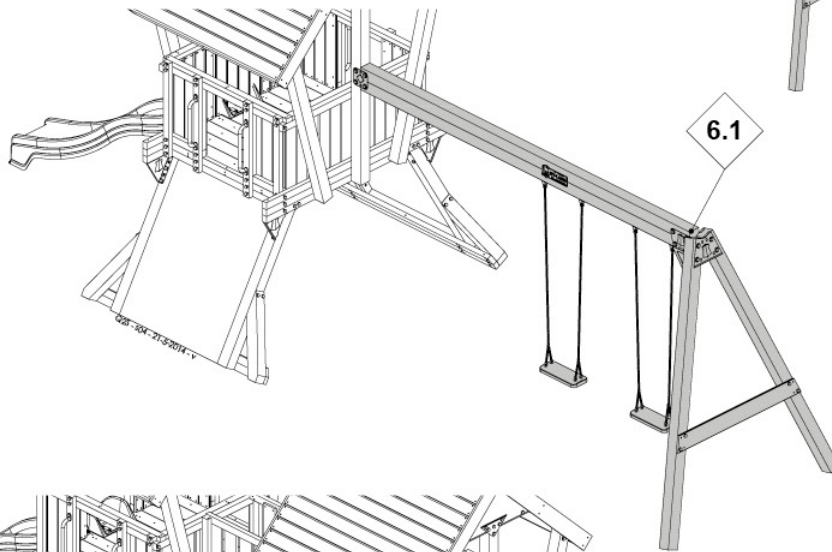

6.1



Q4s

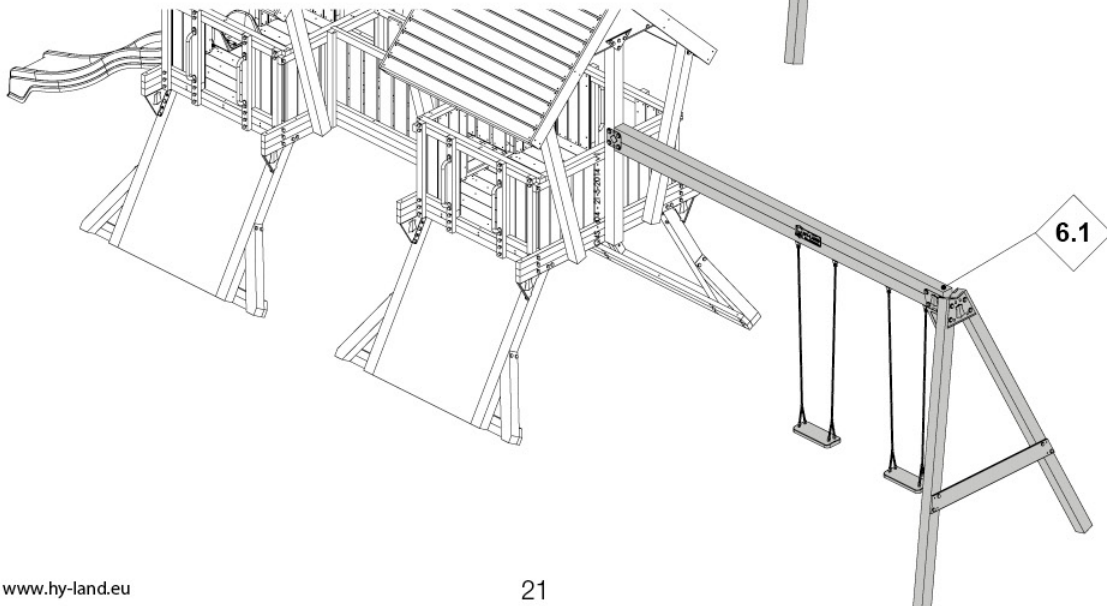

6.1

**6.1a**

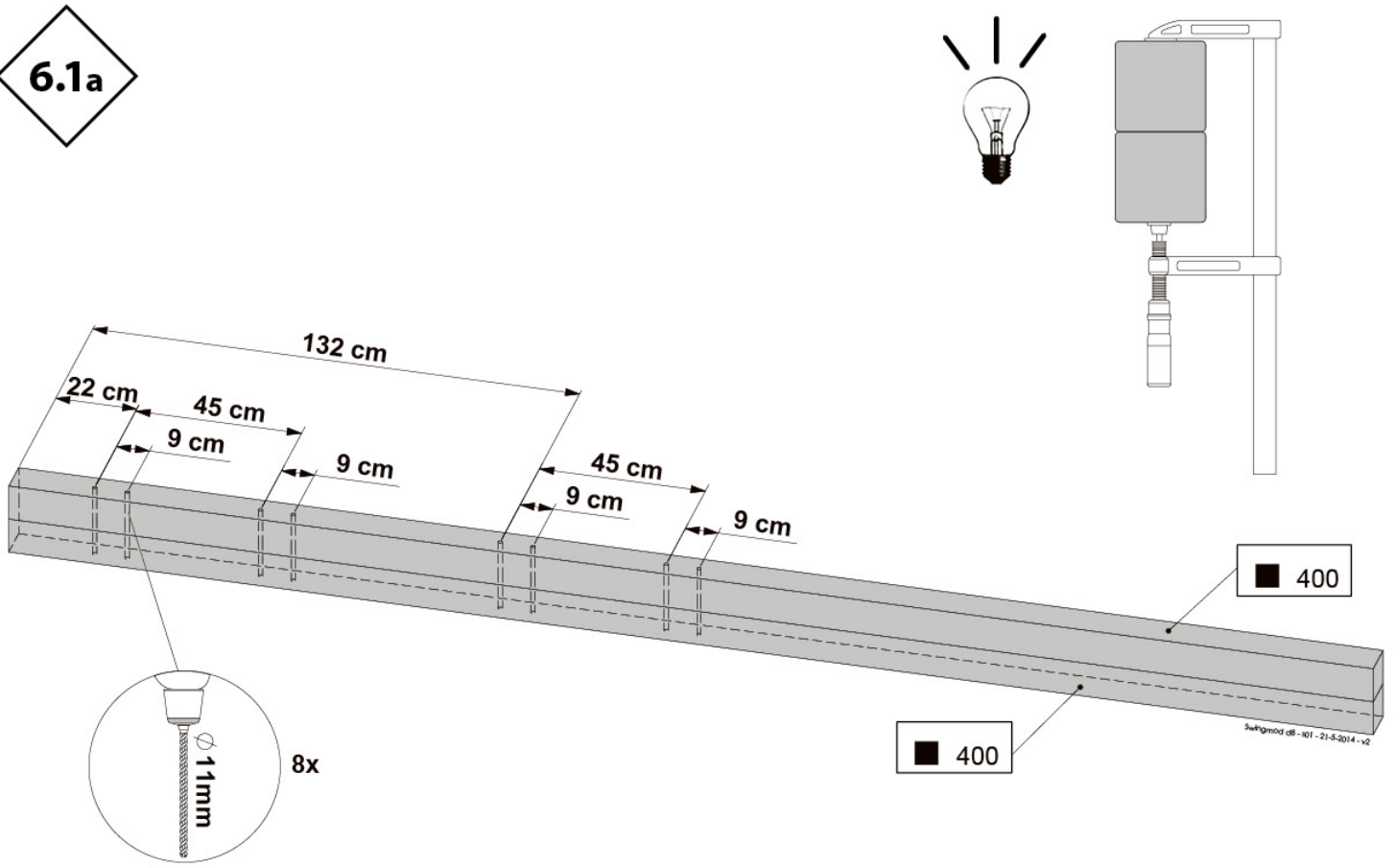

**6.1b**

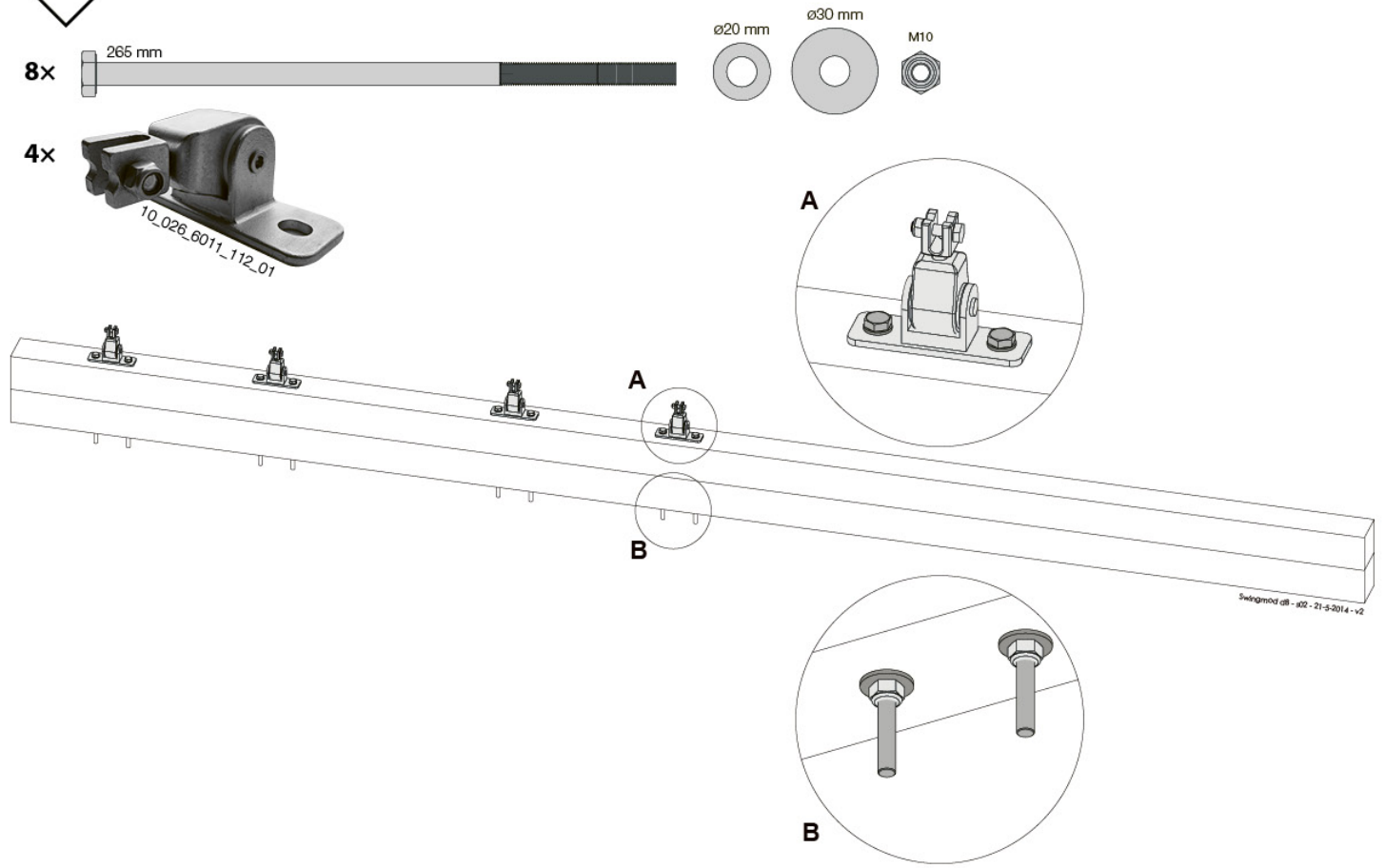

# 6.1c

8x M10

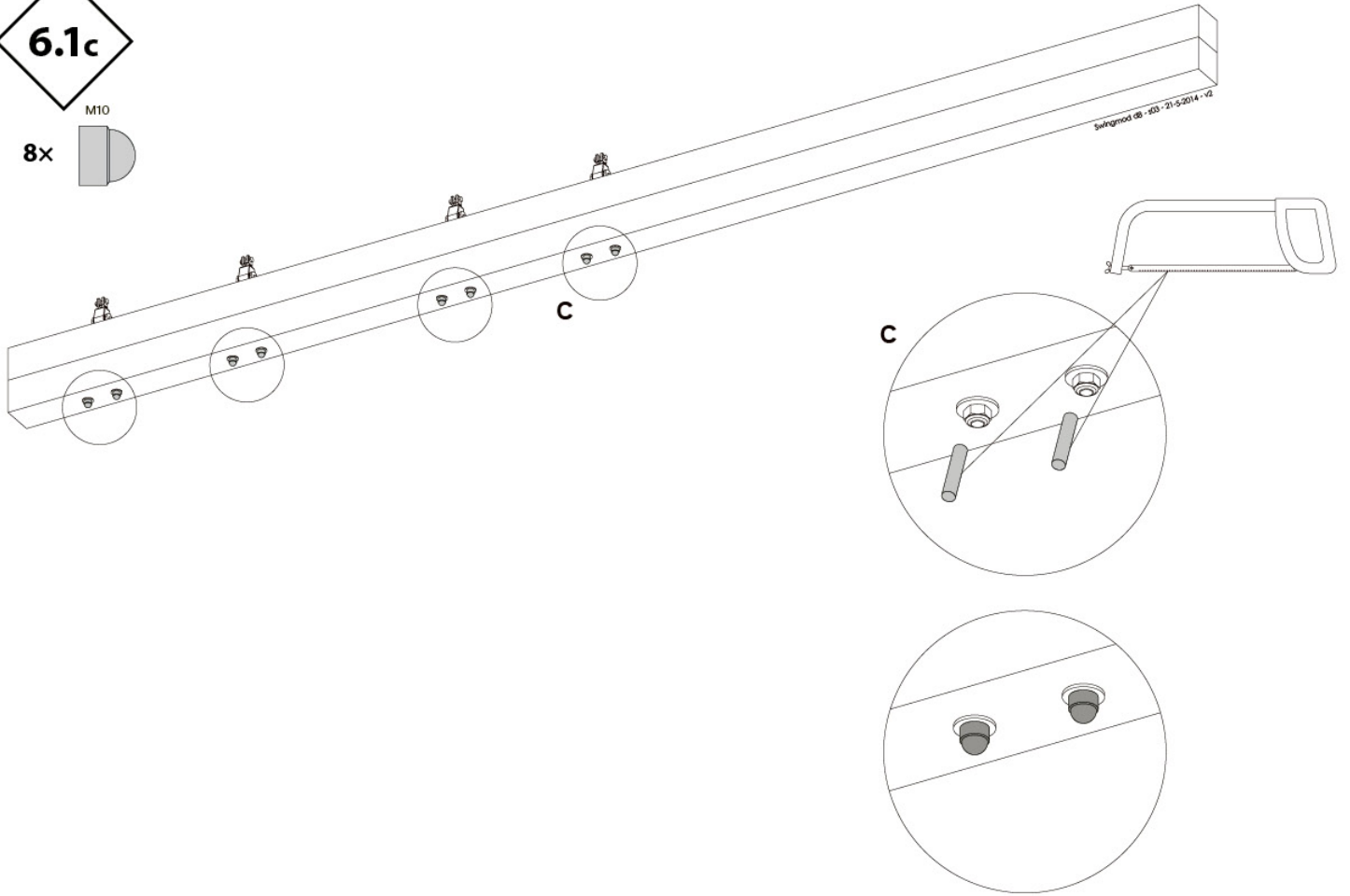

# 6.1d

8x 50 mm  $\varnothing 17$  mm

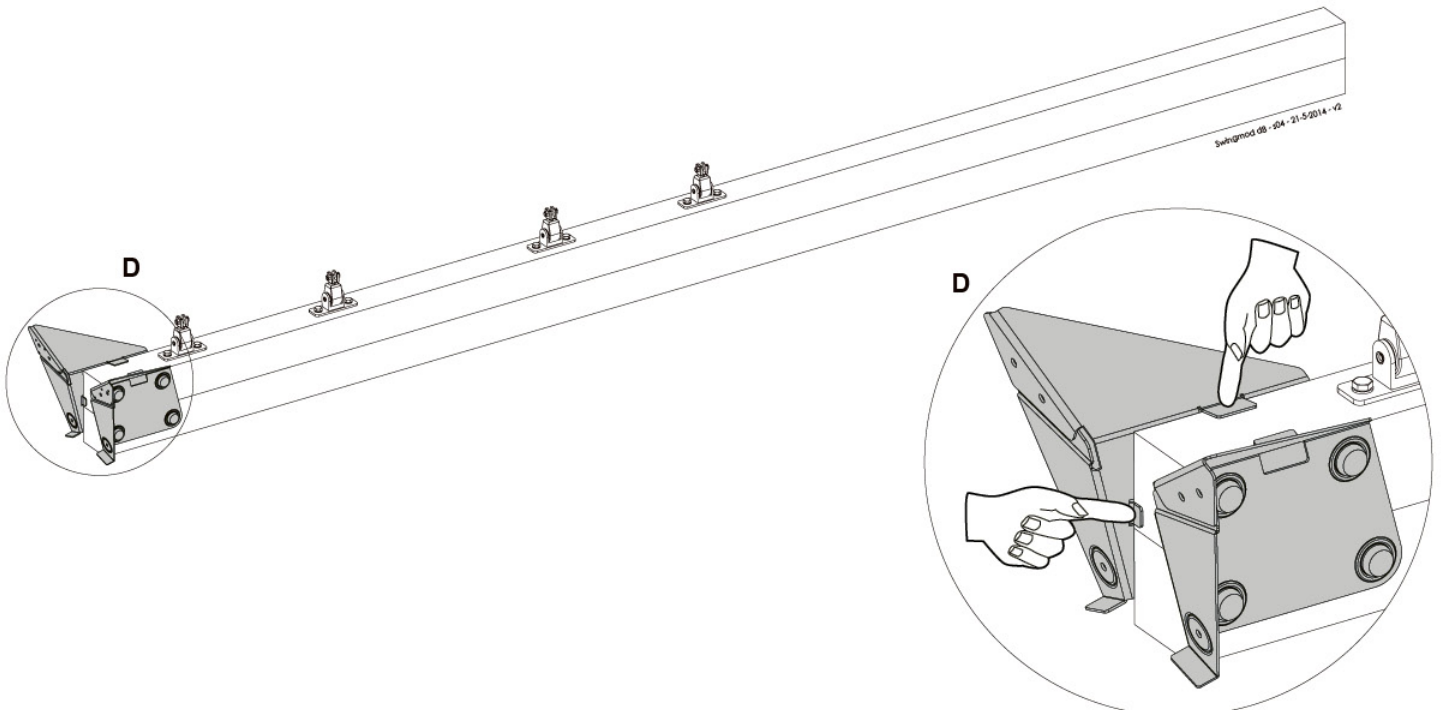
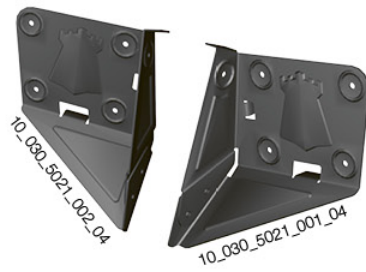

# 6.1e

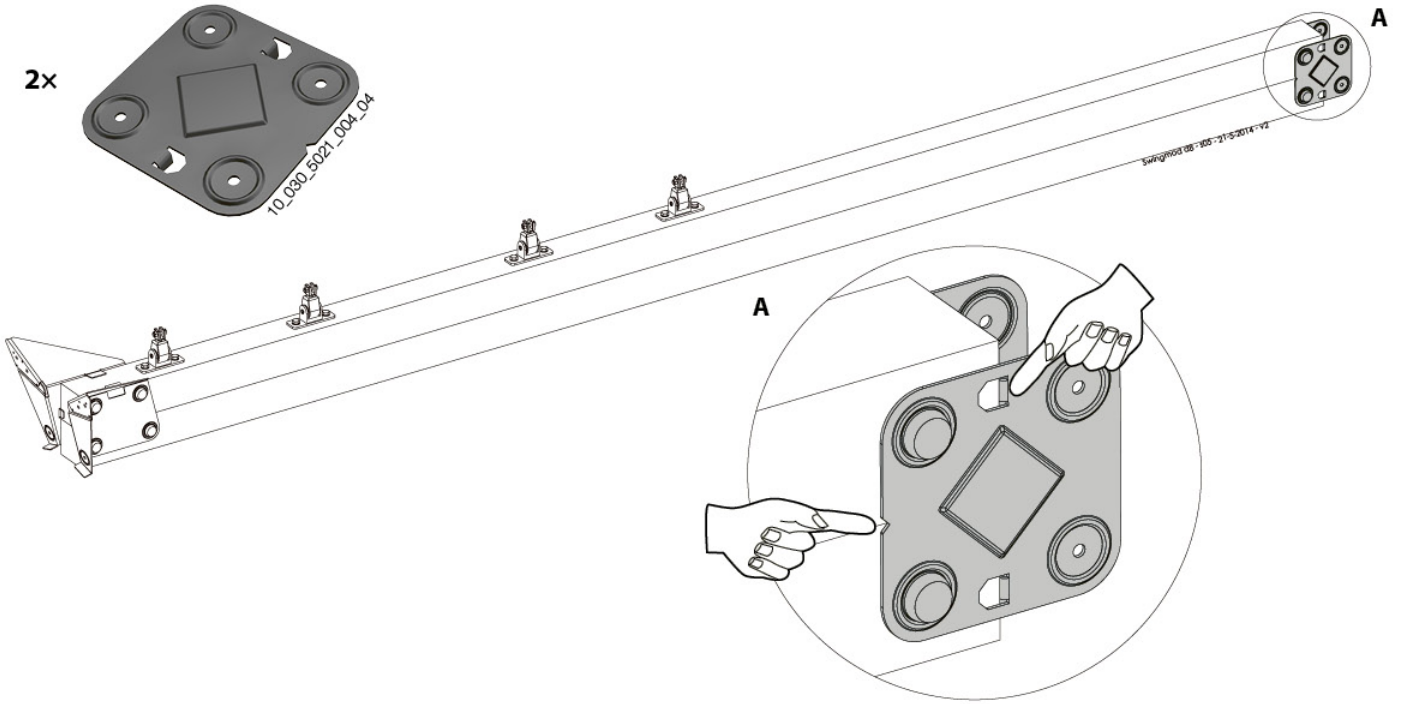
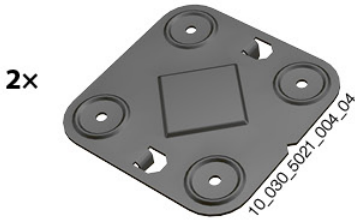
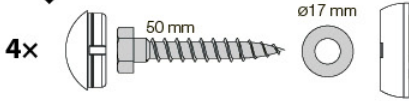

# 6.1f

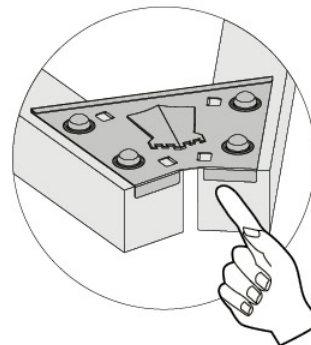
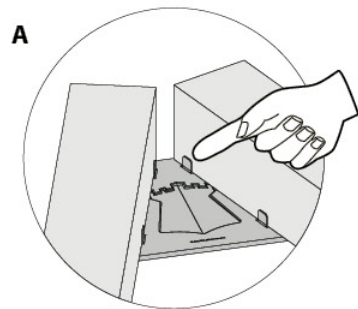
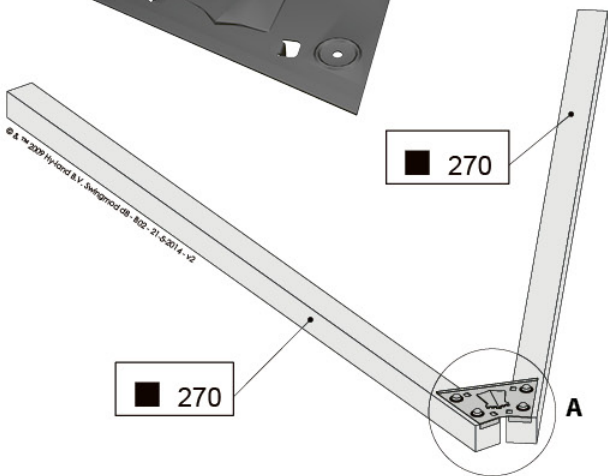
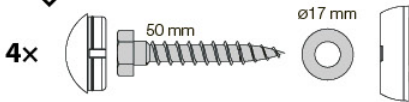



# 6.1g

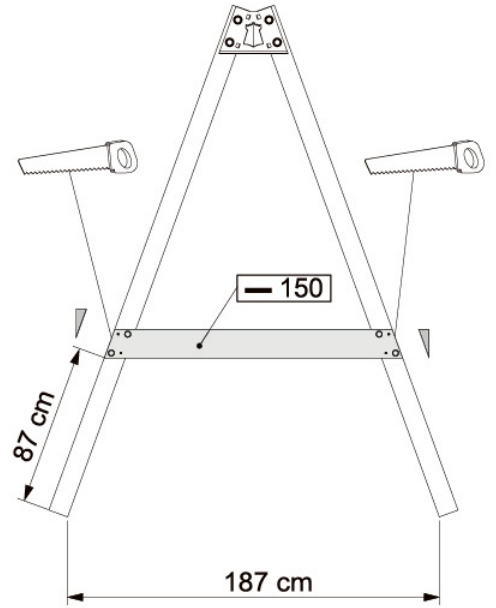
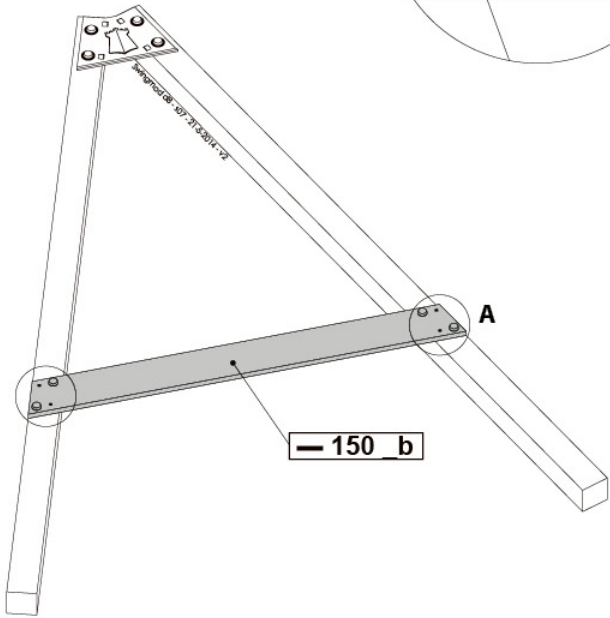
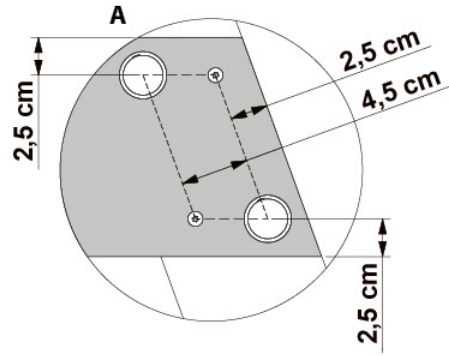
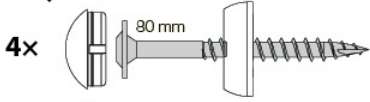

# 6.1h

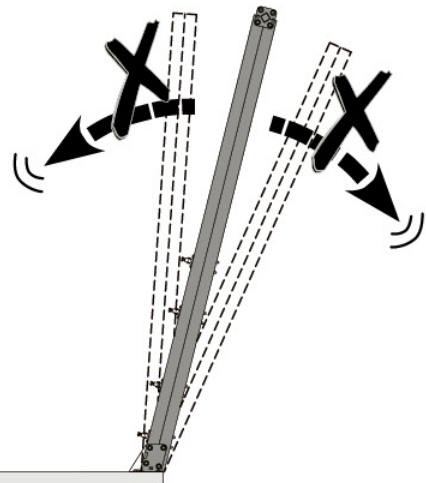
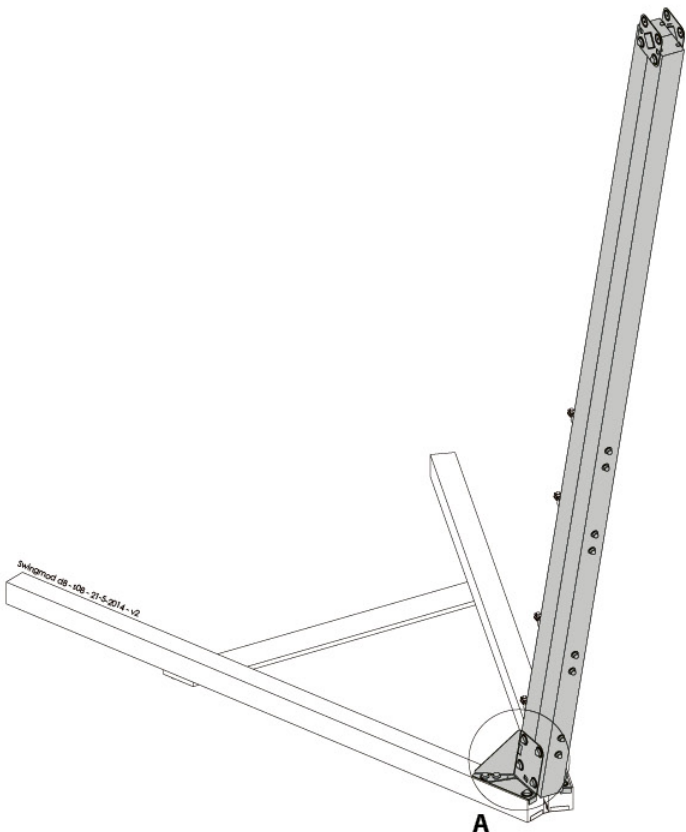
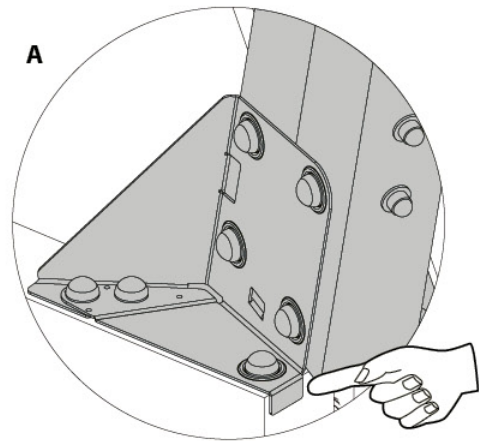
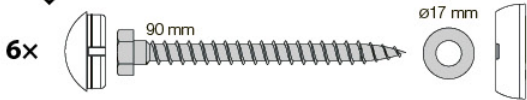

**6.1i**

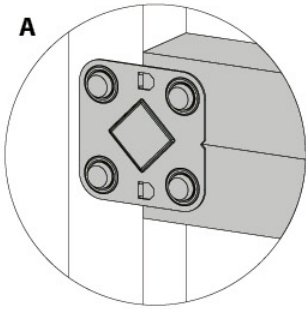

**6.1j**

2x



11\_002\_1020\_101\_25

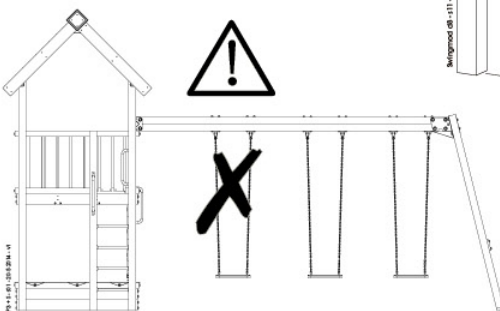
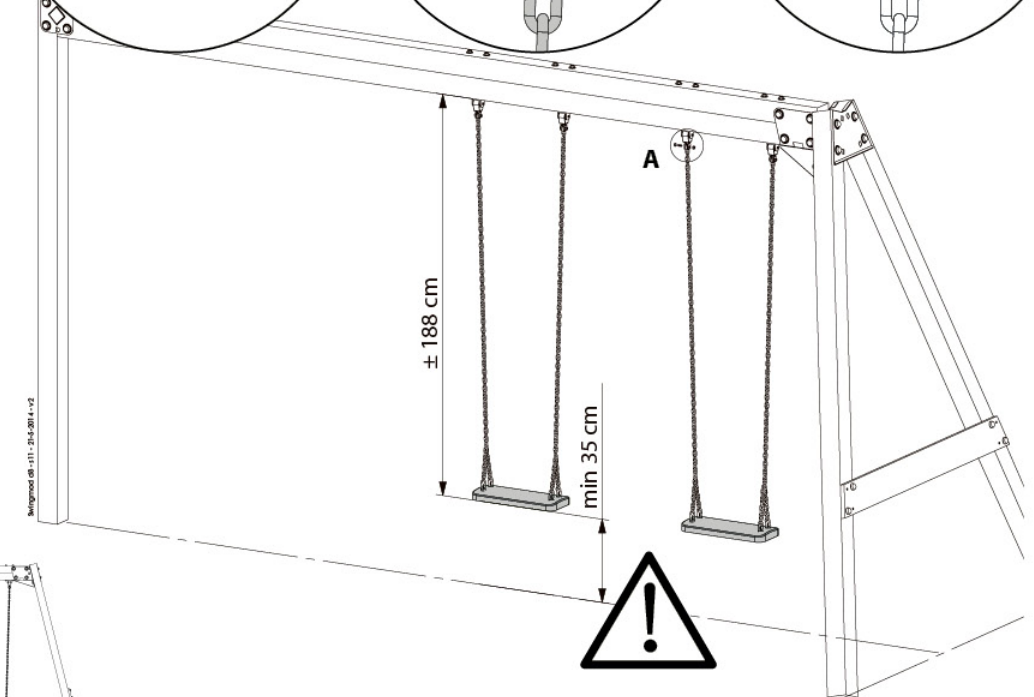
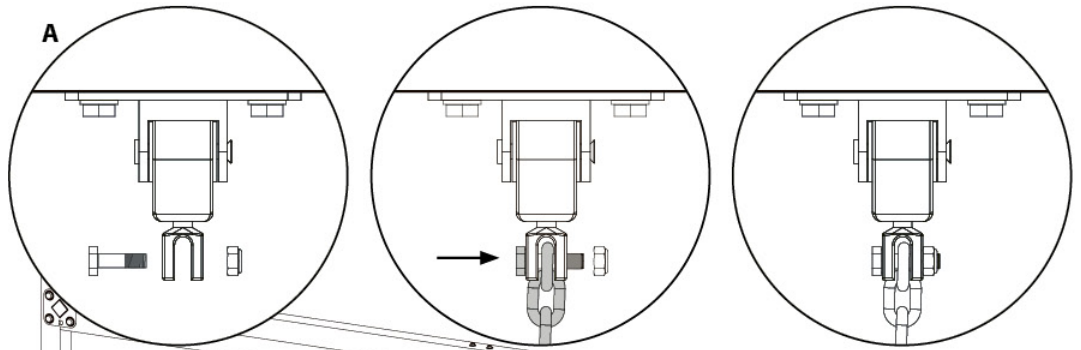

6.1k'

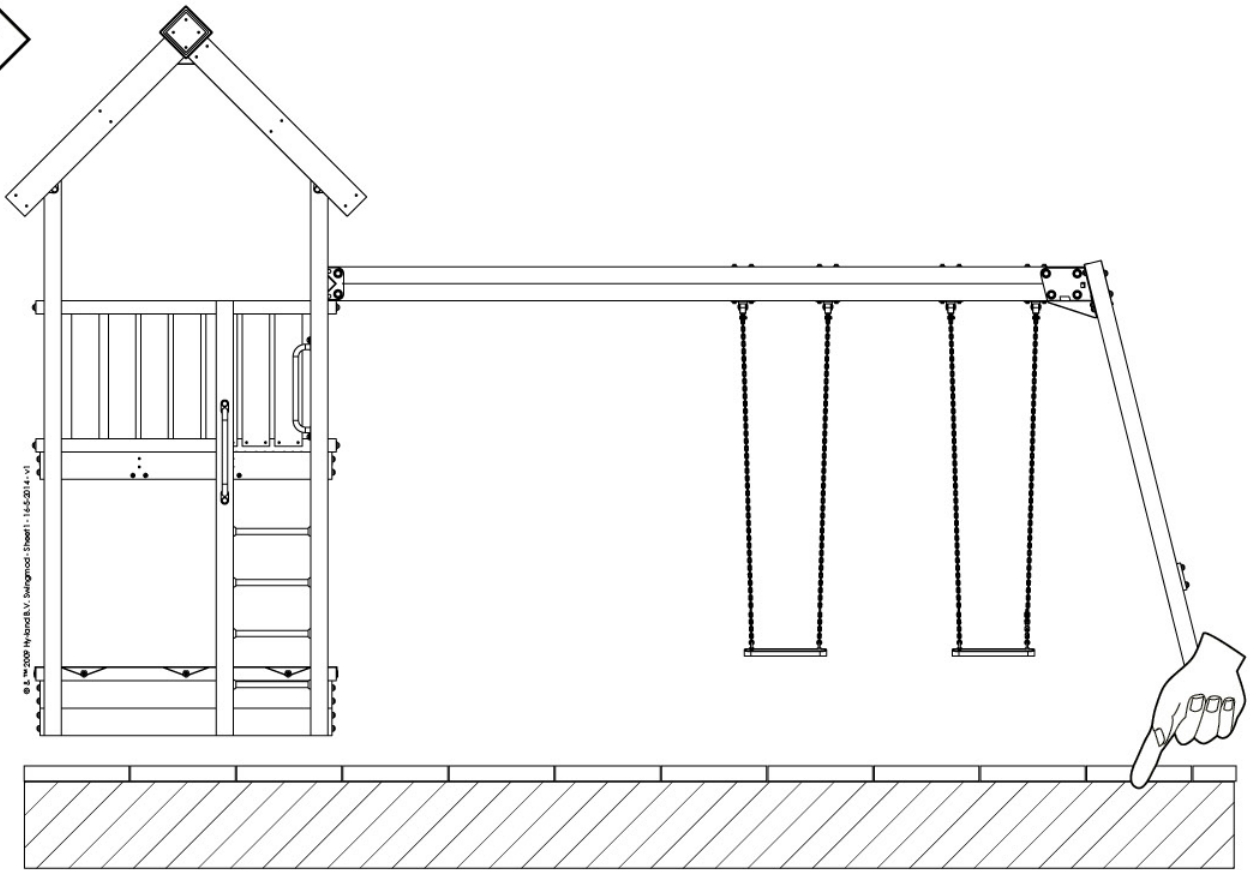

6.1k''

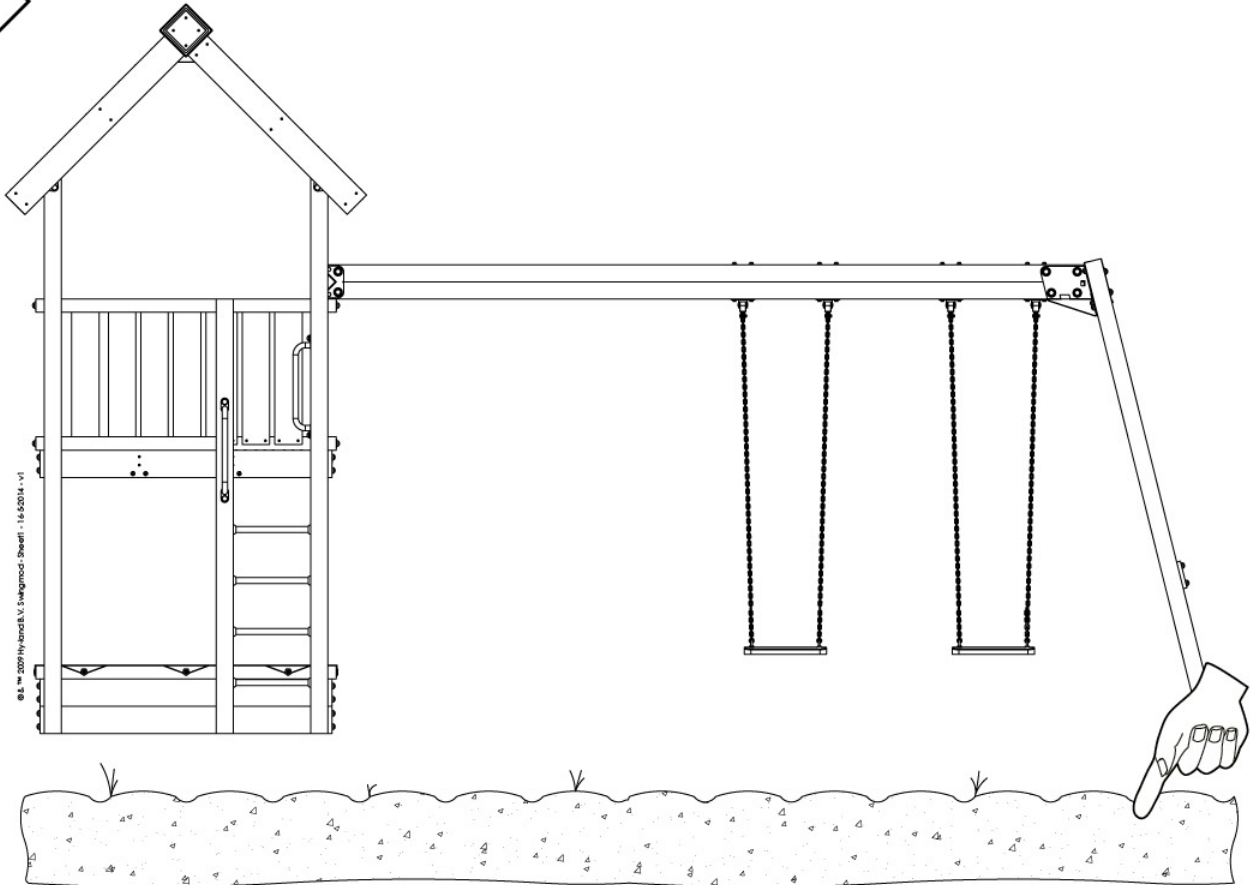

**6.1k'**

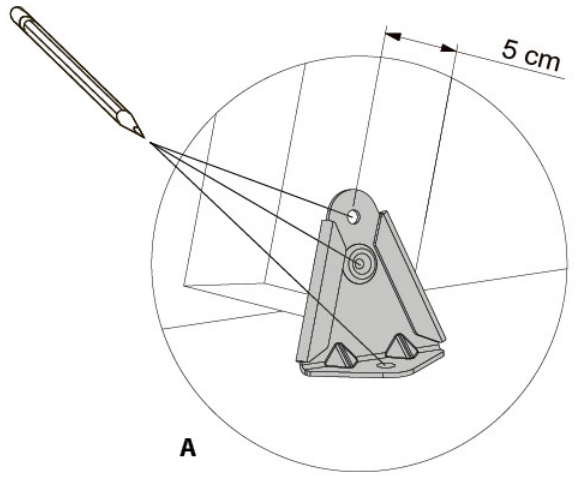
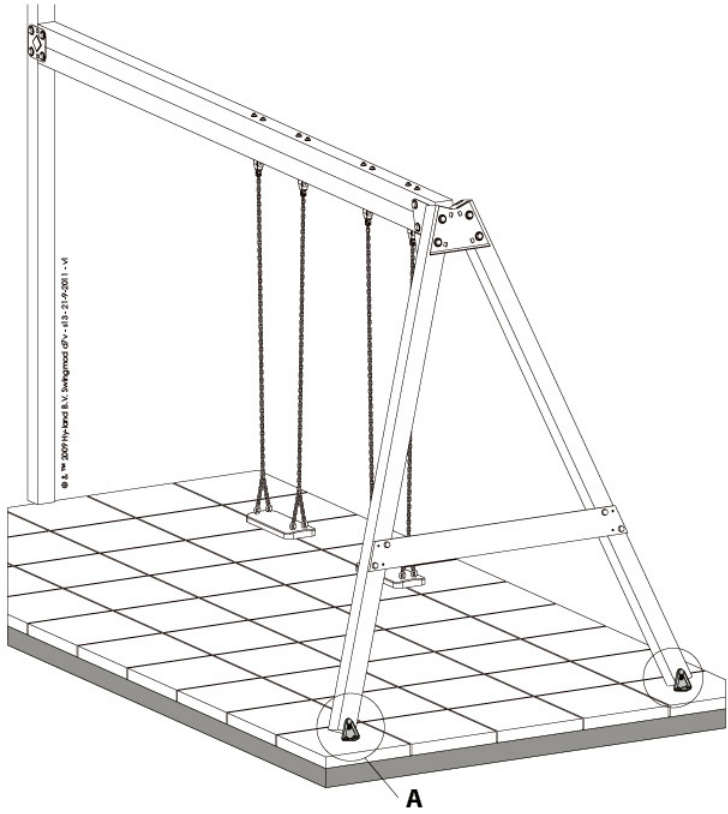

**6.1k''**

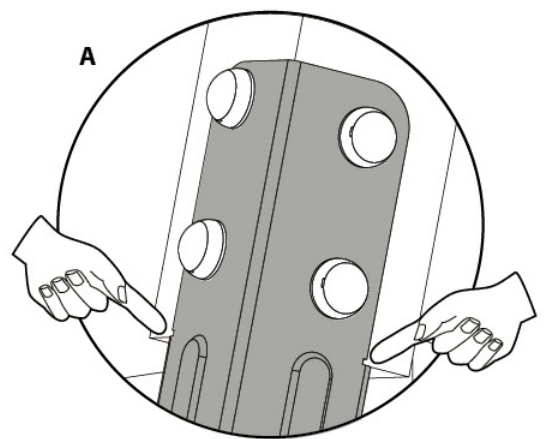
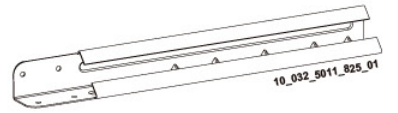
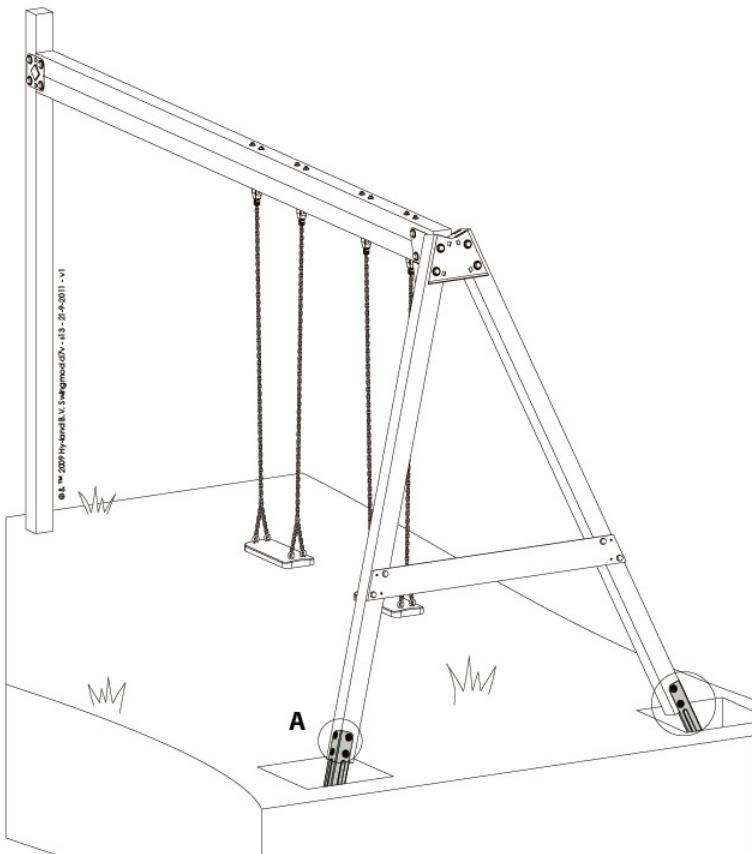

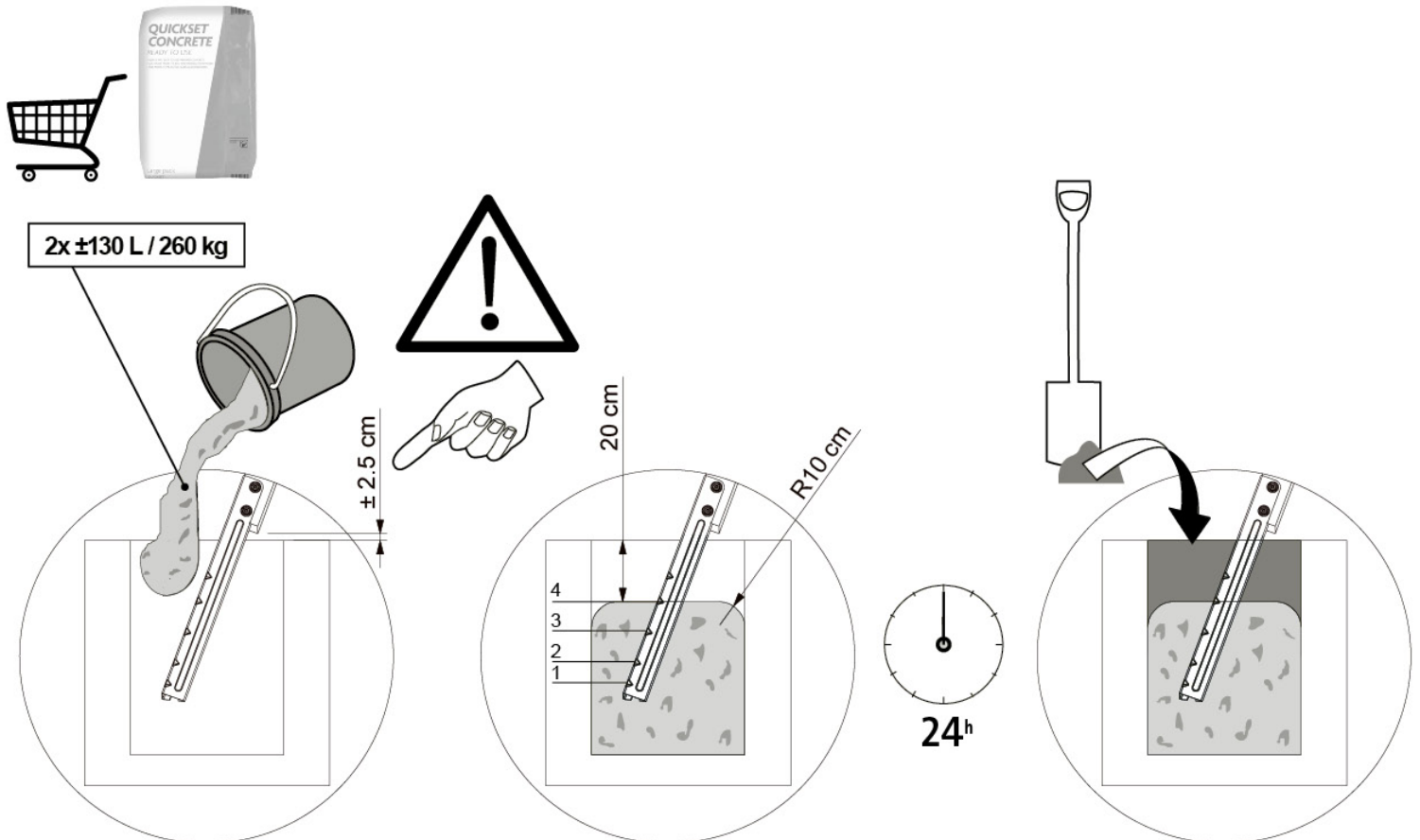
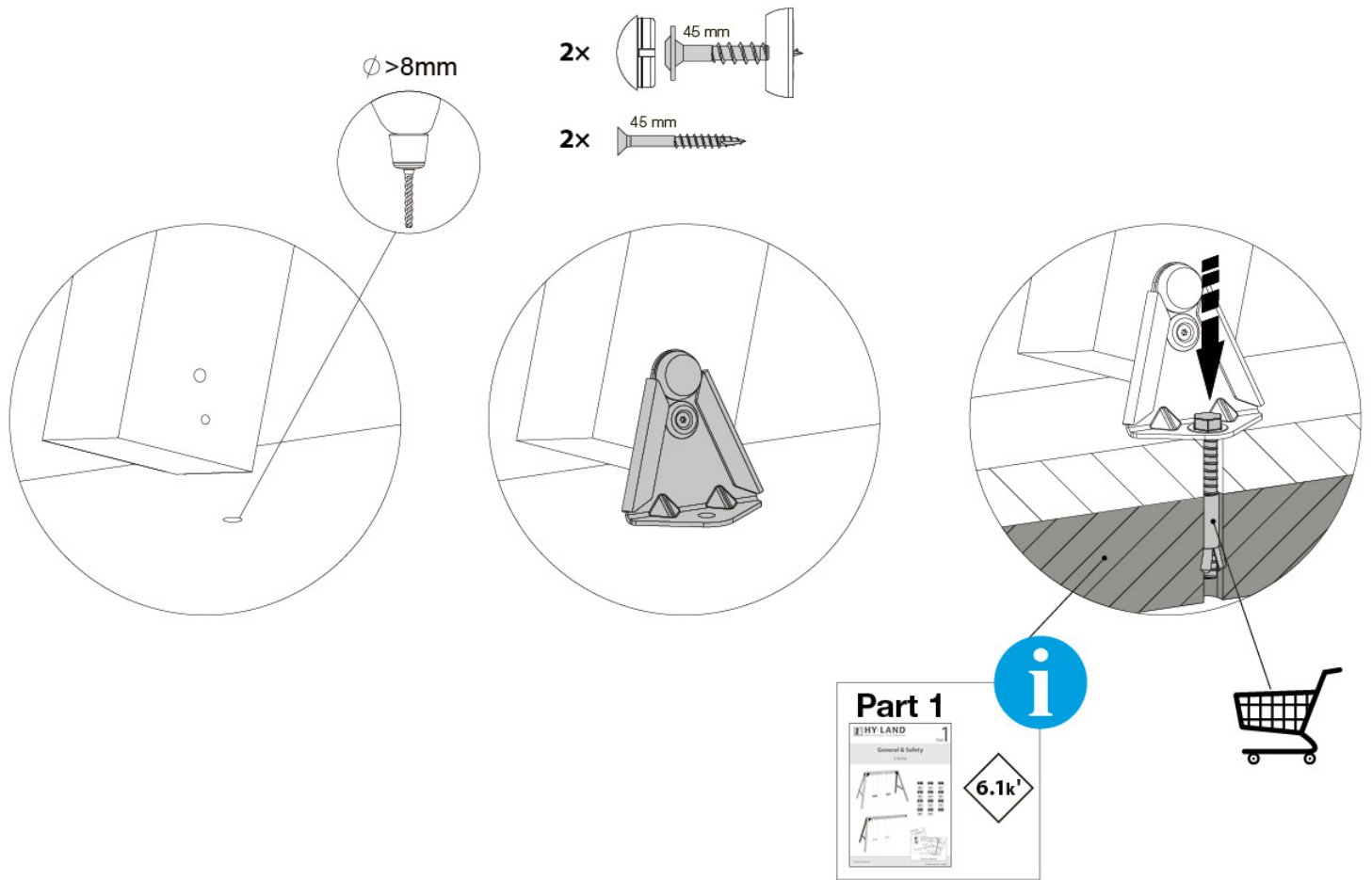

7

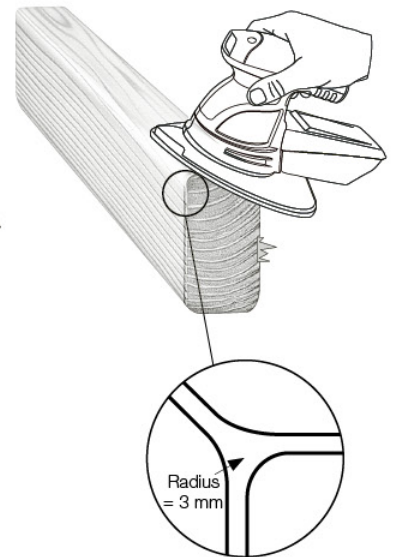
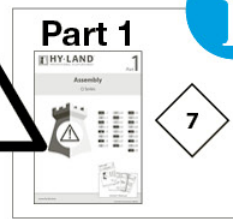
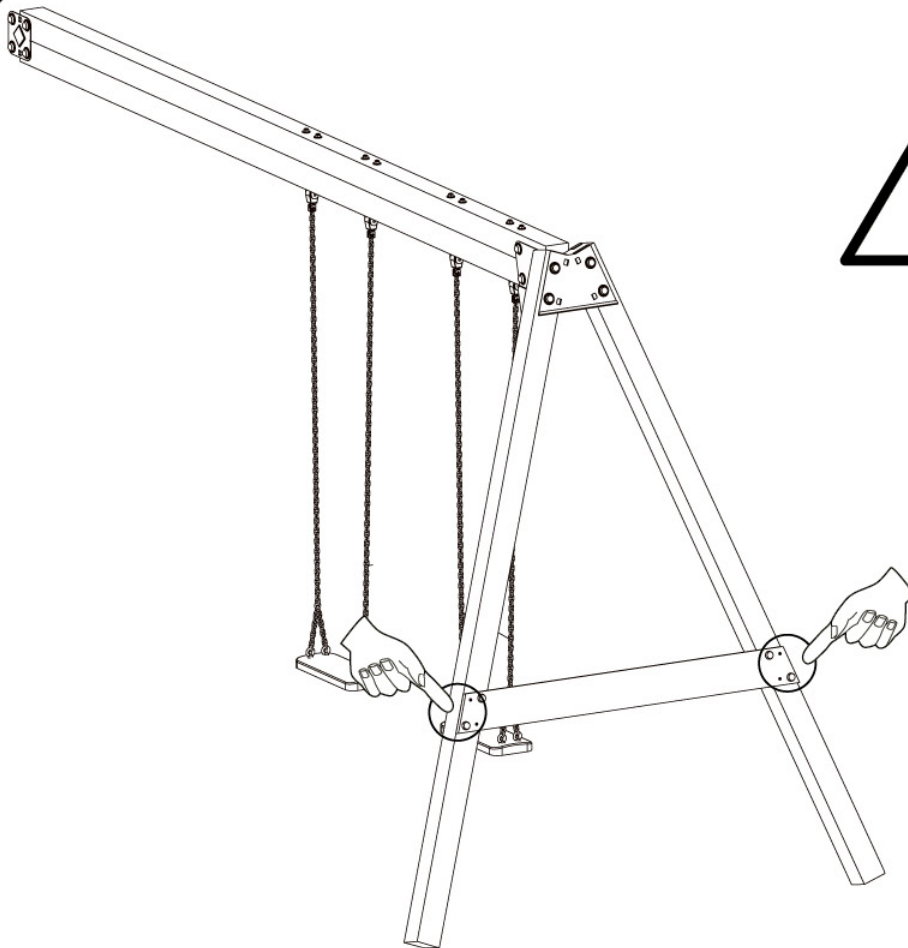

8

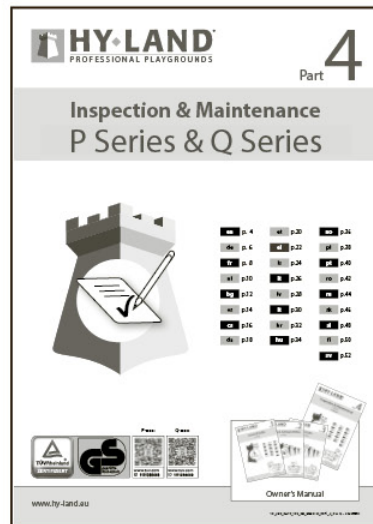

10\_460\_0819\_106\_26



Hy-land B.V.  
P.O. Box 75083  
NL - 1070 AB Amsterdam  
The Netherlands

Tel : +31 85 444 41 01  
Email : [info@hy-land.eu](mailto:info@hy-land.eu)  
URL : [www.hy-land.eu](http://www.hy-land.eu)

Chamber of Commerce :  
NL 16.078.319

